

# **Jamato<sup>®</sup>**

**INDUSTRIAL SEWING MACHINE**

**ILLUSTRATED SPARE PARTS LIST  
OF  
FEED-OFF-THE-ARM MACHINE  
FOR  
FLAT SEAMING**

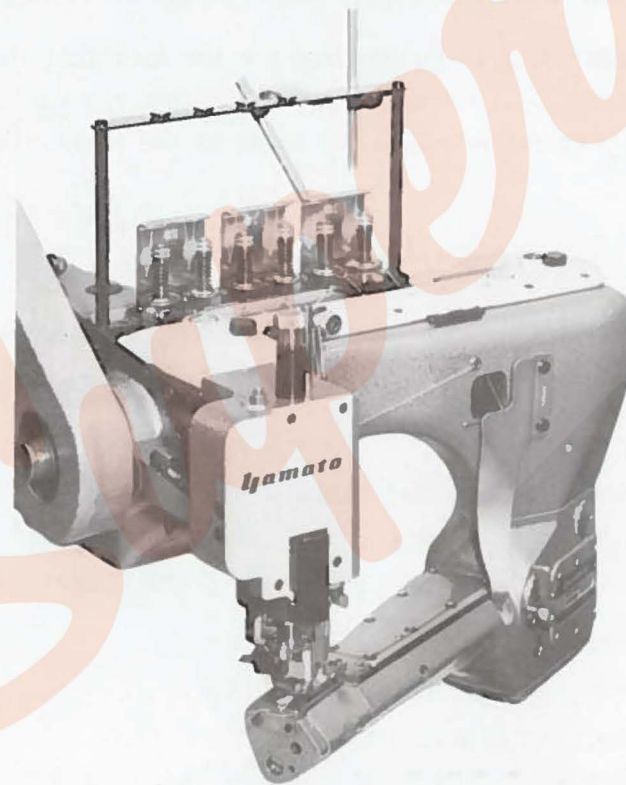

**MODELS**

---

**FD-62-01**

**FD-62-02**

**FD-62-03**

---

## FOR EFFICIENT USE OF THE PARTS BOOK-

Quickly and exactly you will obtain the right object in your hand, by the Parts Book, when certain part of the machine is necessary for replacement or modification, as it shows all of part-names in contrast with their illustrations by each mechanism.

This Book is for the standard model FD-62-01MR of YAMATO's Class FD-62, all parts of which are listed in detail from Page 1 to 14 and successively from Page 15 for machines of sub-models.

Note: \* Parts for sub-models are shown only by those different from the standard model. And, parts in common use with the standard model are not listed except those shown by virtual lines (two-dots chain lines).

By Part Numbers in "INDEX" from Page 18, you can easily check shape of the part and /or its setting position on the machine. When you will order the part you are in need of, it must be placed by the Part Number. Give your attention, please !

Additionally, we beg your kind understanding for the fact that there may be difference in number or shape of some part owing to our continuous researches and improvements, as this Parts Book has been prepared on the basis of the production in July, 1982.

### 〈パーツブックご利用に際して〉

この度は、ヤマトFD-62クラスのマシンをお買上げ頂き、誠にありがとうございます。

このパーツブックは修理交換用の部品や他のモデルに改造する場合等に目的の部品をいち早く捜して頂くため、分かり易く機構別にイラストと表を対比して掲載しております。

すなわち、FD-62-01MRを基本モデルとし、1ページから14ページまでを基本モデル、15ページからサブモデルの部品を掲載しております。このサブモデルの部品構成は、基本モデルと異なる部品のみを掲載しており、仮想線（2点鎖線）及び無掲載の部品は基本モデルと共通使用のものでありますから、この点ご注意ください。

部品番号で部品の形状や、マシンのどの部分に組込まれている部品か等をお調べの場合は18ページからの索引(INDEX)にて簡単に引き出せます。

部品をお求めの際は部品番号でお間違いのないようお願いいたします。

なお、このパーツブックは1982年7月現在製造中のマシンを基本に作成しております。品質性能に関しましては絶えず研究し、日々改良を加えておりますので部品番号及び形状等が異なる場合がありますからご了承ください。

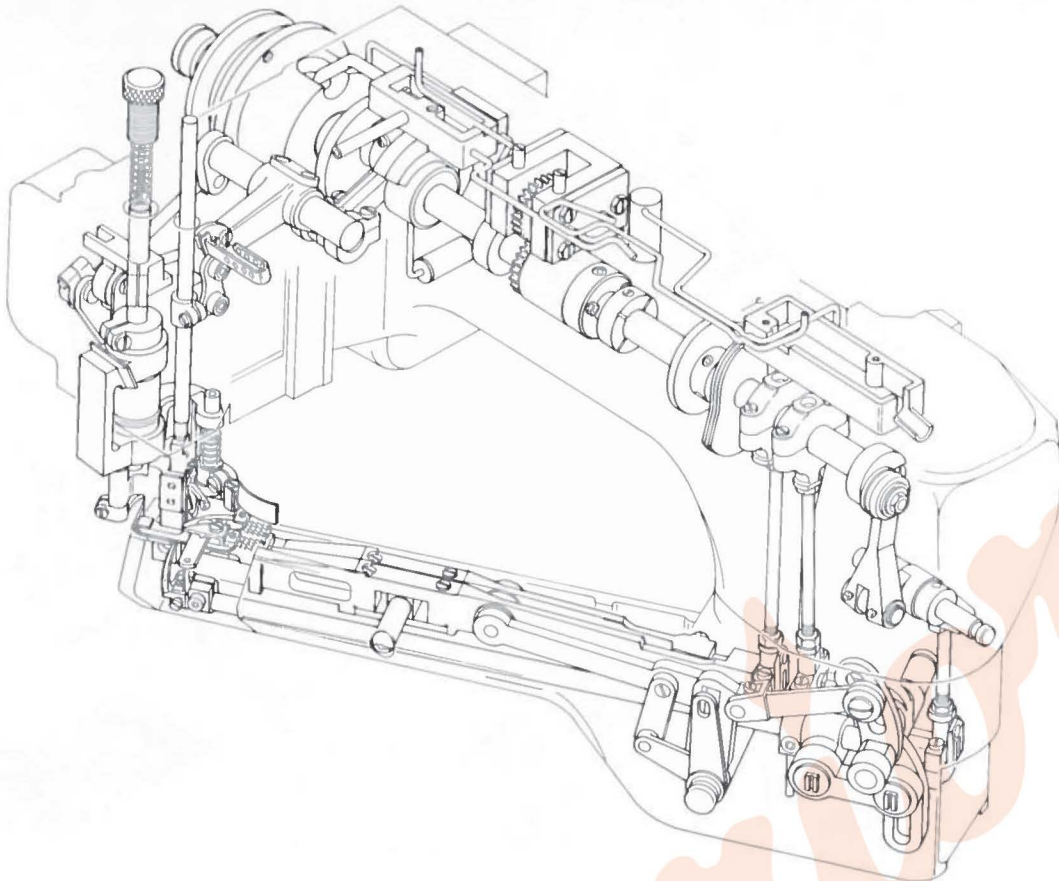

PERSPECTIVE  
透視図

## CONTENTS

## 目次

MISCELLANEOUS COVERS (1) .....	カバー関係(1).....	1
MISCELLANEOUS COVERS (2) .....	カバー関係(2).....	2
MISCELLANEOUS THREAD EYELETS .....	糸道関係.....	3
MISCELLANEOUS BUSHINGS .....	ブッシュ関係.....	4
CRANKSHAFT & NEEDLE BAR DRIVING MECHANISM .....	シャフト及び針棒機構.....	5
PRESSER FOOT MECHANISM .....	押工機構.....	6
UPPER KNIFE, CARRIER AND HOOK DRIVING MECHANISM.....	上メス及びキャリア・フック機構.....	7
LOOPER DRIVING MECHANISM.....	ルーバ機構.....	8
FEED DRIVING MECHANISM.....	送り機構.....	9
FEED DRIVING CONTROL MECHANISM .....	送り調節機構.....	10
LUBRICATING MECHANISM .....	給油機構.....	11
SEWING MACHINE PEDESTAL (1) .....	ペDESTアル(1).....	12
SEWING MACHINE PEDESTAL (2) .....	ペDESTアル(2).....	13
THREAD STAND .....	糸立台.....	14
FD-62-02 EXCLUSIVE PARTS .....	サブモデル専用部品.....	15
FD-62-03 EXCLUSIVE PARTS .....	サブモデル専用部品.....	16
EXTRA PARTS for FDL-1 and EXTRA TOOLS & GAUGES .....	特注部品及び特注工具, ゲージ.....	17
INDEX.....	索引.....	18

Illustration of this Parts Book is based on the Model FD-62-01MR.  
このパーツブックはFD-62-01MRを基本にしてイラストを作成しております。

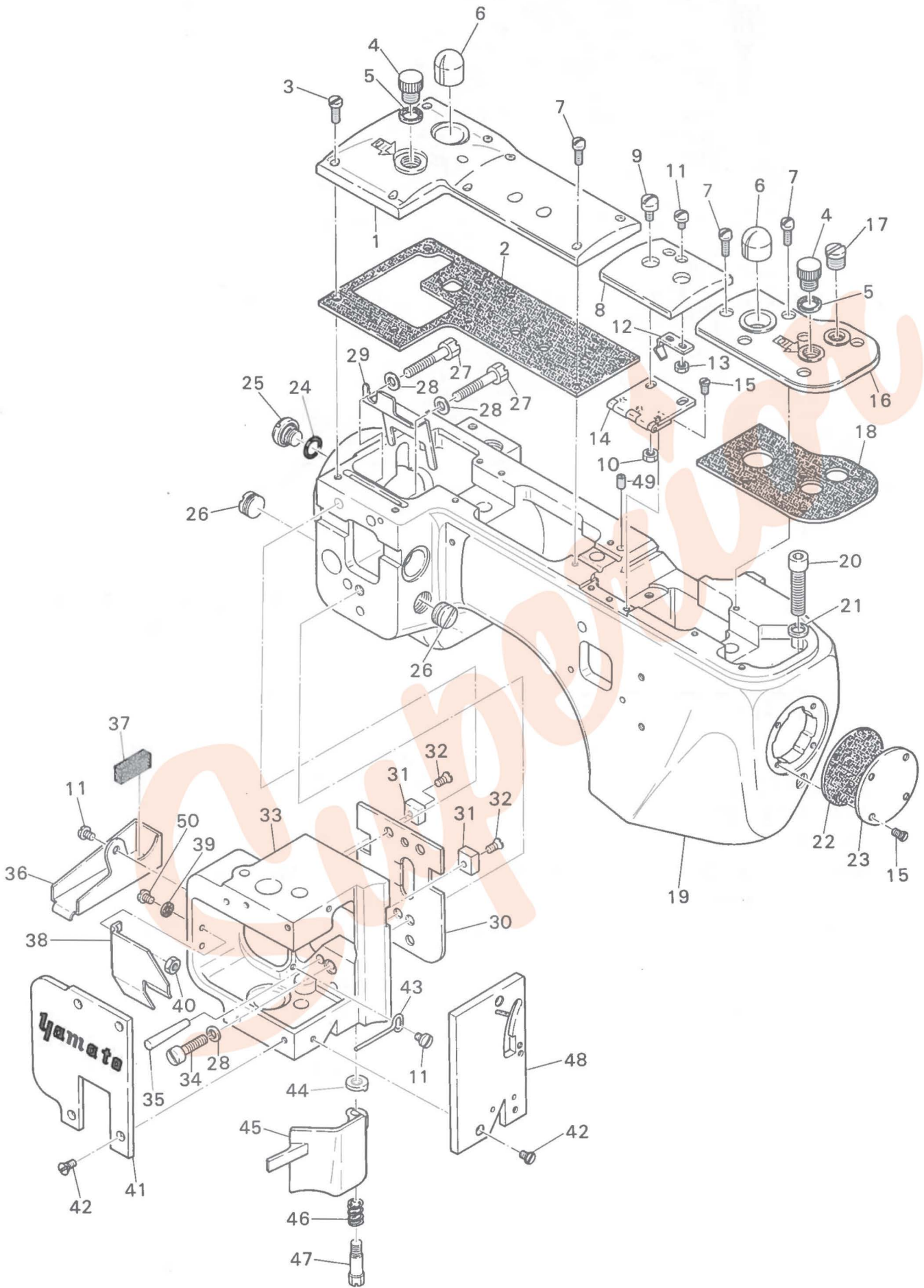

Ref. No.	Parts No.	Description	品名	Amt. Req.
1	68008	Crank Chamber Cover	クランク室カバー	1
2	68009	Crank Chamber Cover Gasket	クランク室カバーパッキン	1
3	4445	Screw for 68008	クランク室カバー止ネジ	5
4	4192	Screw for 68008	クランク室カバープラグネジ	2
5	484	Washer for 68008	ワッシャ	2
6	68011	Oil Sight Top Window	オイル確認窓	2
7	4352	Screw for 68008, 68018	止ネジ	10
8	68012	Top Cover (Middle)	フレーム上カバー(中)	1
9	9853	Screw for 68012	フレーム上カバー止ネジ	2
10	340	Nut for 68012	ナット	2
11	4358	Screw for 68013, 68306, 68308	止ネジ	4
12	68013	Top Cover (Middle) Spring	フレーム上カバー(中)バネ	1
13	322	Nut for 68013	ナット	2
14	68014	Top Cover (Middle) Hinge	フレーム上カバー(中)ヒンジ	1
15	4184	Screw for 68014, 68020	止ネジ	7
16	68018	Top Cover (Front)	フレーム上カバー(前)	1
17	4196	Plug Screw for 68018	フレーム上カバー(前)プラグネジ	1
18	68019	Top Cover (Front) Gasket	フレーム上カバー(前)パッキン	1
19	68001	Machine Frame	フレーム	1
20	9104	Screw for 68005	シリンダ止ネジ	3
21	472	Washer for 68005	ワッシャ	3
22	68021	Machine Frame End Cover Gasket	フレームエンドカバーパッキン	1
23	68020	Machine Frame End Cover	フレームエンドカバー	1
24	32421	Drain Hole Seal	ベース油抜キリング	1
25	5076	Drain Hole Screw	油抜キネジ	1
26	4195	Plug Screw for 68001	フレームプラグネジ	2
27	4175	Screw for 68002	ソーイングヘッド止ネジ	2
28	474	Washer for 68002	ワッシャ	3
29	68307	Crank Chamber Cover Oil Shield	クランク室油除ケ	1
30	68004	Sewing Head Oil Defense	ソーイングヘッド防油板	1
31	68003	Sewing Head Key	ソーイングヘッドキー	2
32	7621	Screw for 68003	ソーイングヘッドキー止ネジ	2
33	68002	Sewing Head	ソーイングヘッド	1
34	4174	Screw for 68002	ソーイングヘッド止ネジ	1
35	479	Pin for 68002	テーパピン	1
36	68306	Knife Driving Connection Oil Guard	上メスロッド油受ケ	1
37	68323	Knife Driving Connection Felt	上メスロッドフェルト	1
38	68354	Thread Carrier and Hook Driving Rod Oil Guard	キャリア・フックロッド油除ケ	1
39	187	Seal for 68354	パッキン	2
40	335	Nut for 68354	ナット	2
41	68023	Sewing Head Cover (Left)	ソーイングヘッド横カバー	1
42	9142	Washer for 68023, 68022	止ネジ	6
43	68308	Oil Guide Wire	オイルガイドワイヤ	1
44	68196	Frame Chip Guard Washer	フレームチップガードワッシャ	1
45	68191	Frame Chip Guard	フレームチップガード	1
46	68193	Frame Chip Guard Spring	フレームチップガードバネ	1
47	4188	Screw for 68191	フレームチップガード止ネジ	1
48	68022	Sewing Head Cover (Front)	ソーイングヘッド前カバー	1
49	93059	Oil Seal Plug	埋メ座	1
50	4353	Screw for 68354	キャリア・フックロッド油除ケ止ネジ	2

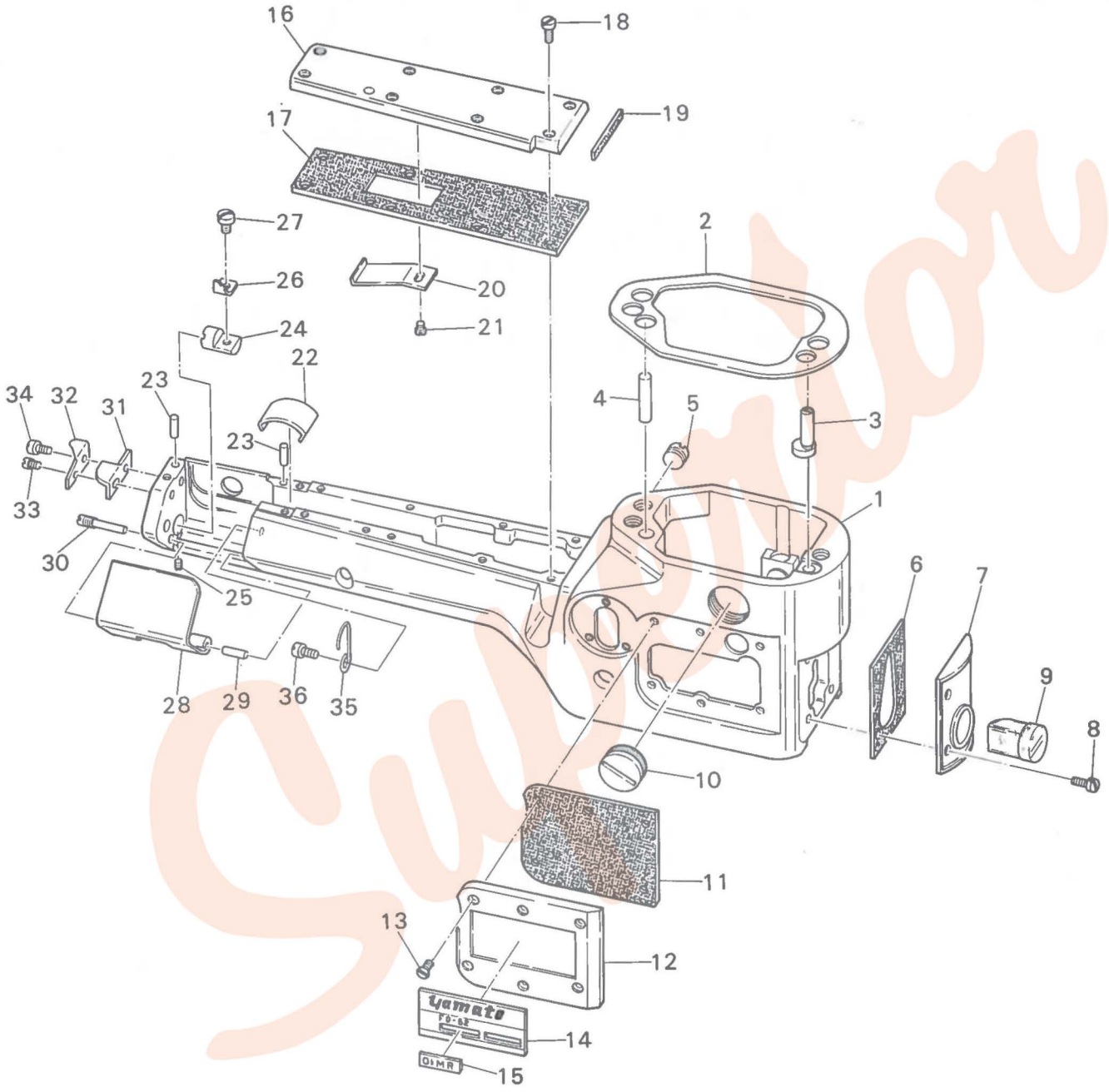

Ref. No.	Parts No.	Description	品名	Amt. Req.
1	68005	Sewing Cylinder	シリンダ	1
2	68006	Sewing Cylinder Gasket	シリンダパッキン	1
3	68007	Sewing Cylinder Alignment Eccentric Pin	シリンダ調節エキセンピン	1
4	478	Knock Pin for 68005	シリンダノックピン	1
5	4194	Plug Screw for 68005	シリンダプラグネジ(右)	1
6	68031	Sewing Cylinder Cover (Front) Gasket	シリンダ前カバーパッキン	1
7	68030	Sewing Cylinder Cover (Front)	シリンダ前カバー	1
8	4312	Screw for 68030	シリンダ前カバー止ネジ	4
9	68032	Sewing Cylinder Oil Gauge	シリンダオイルゲージ	1
10	4193	Plug Screw for 68005	シリンダプラグネジ(左)	1
11	68339	Sewing Cylinder Cover (Left) Gasket	シリンダ横カバーパッキン	1
12	68338	Sewing Cylinder Cover (Left)	シリンダ横カバー	1
13	7621	Screw for 68338	シリンダ横カバー止ネジ	6
14	68330	Model Plate	型式板	1
15-1	68400	Gauge Indicate Plate (01MR)	ゲージ記号板(01MR)	1
15-2	68475	" " " (02MR)	" (02MR)	1
15-3	68433	" " " (03MR)	" (03MR)	1
16	68024	Sewing Cylinder Cover (Upper)	シリンダ上カバー	1
17	68025	Sewing Cylinder Cover (Upper) Gasket (Large)	シリンダ上カバーパッキン(大)	1
18	4134	Screw for 68024	シリンダ上カバー止ネジ	8
19	68026	Sewing Cylinder Cover (Upper) Gasket (Small)	シリンダ上カバーパッキン(小)	1
20	68027	Dust Defender (Upper)	送り台埃り除ケ(上)	1
21	4141	Screw for 68027	送り台埃り除ケ止ネジ	1
22	68094	Dust Defender (Lower)	送り台埃り除ケ(下)	1
23	480	Pin for Stitch Plate	針板位置決めピン	2
24	68227	Looper Cover Spring Support	ルーバカバーバネ取付台	1
25	7650	Screw for 68227	ルーバカバーバネ取付台止ネジ	1
26	68226	Looper Cover Spring	ルーバカバーバネ	1
27	1203	Screw for 68226	ルーバカバーバネ止ネジ	1
28	68225	Looper Cover	ルーバカバー	1
29	486	Pin for 68225	ルーバカバーヒンジピン	1
30	4190	Screw for 68225	ルーバカバー止ネジ	1
31	68271	Chain-off Cutting Knife	チェインカッタ	1
32	68272	Chain-off Cutting Knife Guard	チェインカッタガード	1
33	3410	Positioning Screw for 68272	チェインカッタガード位置決めネジ	1
34	1196	Screw for 68272	チェインカッタガード止ネジ	1
35	68265	Looper Thread Guide Wire	ルーバ糸ガイドワイヤ(下)	1
36	7405	Screw for 68265	ルーバ糸ガイドワイヤ(下)止ネジ	1

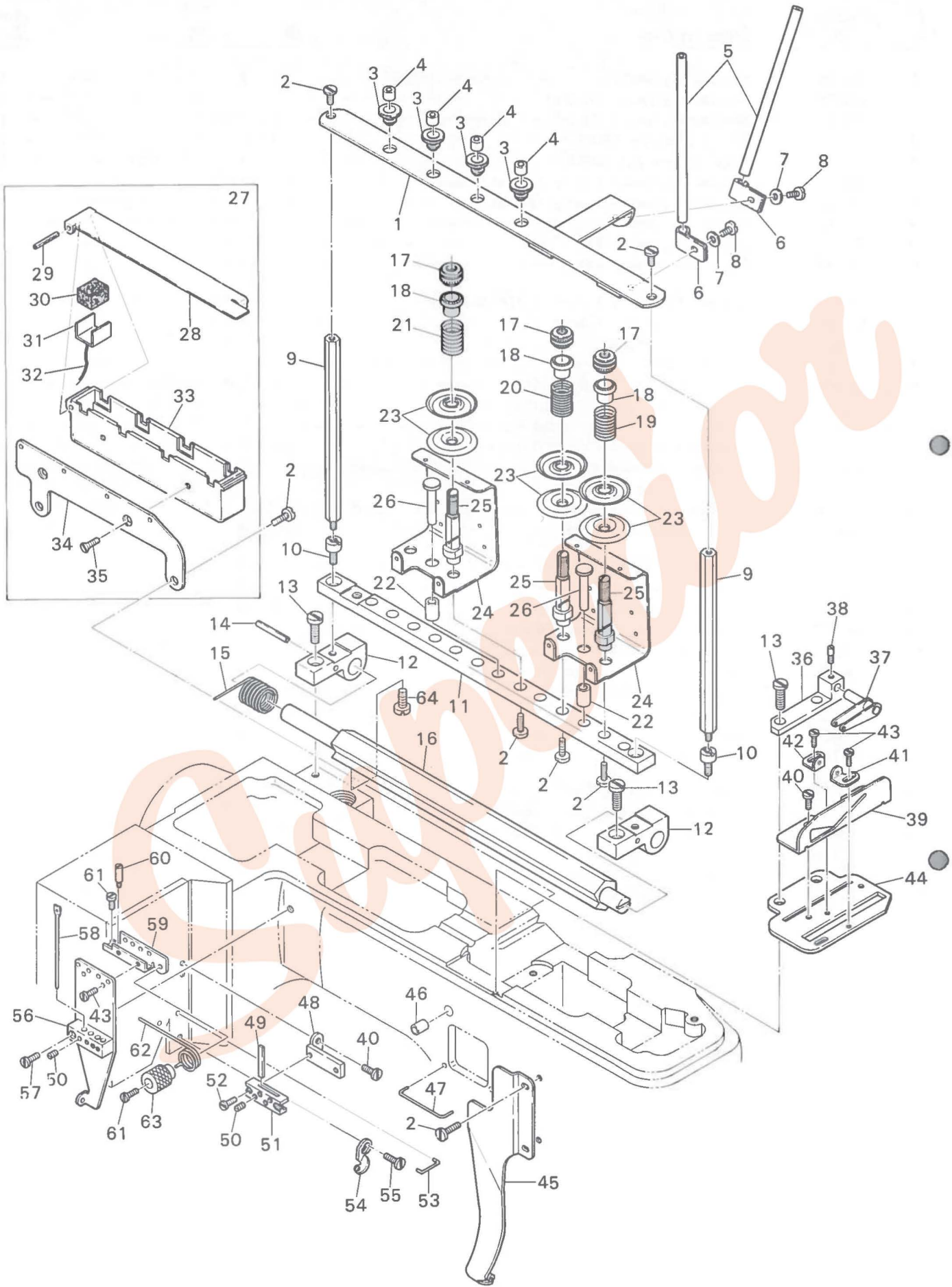



Ref. No.	Parts No.	Description	品名	Amt. Req.
1	68356	Thread Guide Plate	糸案内板	1
2	4440	Screw for 68356, 4206, 68351, 68262	止ネジ	12
3	68359	Thread Eyelet Bushing	糸案内糸道ブッシュ	4
4	68358	Thread Eyelet	糸案内糸道	4
5	93538	Thread Pipe	糸道パイプ	2
6	93528	Thread Pipe Stay	糸道パイプ支エ	2
7	532	Washer for 93528	ワッシャ	2
8	4358	Screw for 93528	糸道パイプ支エ止ネジ	2
9	68357	Thread Guide Plate Support	糸案内板支エ棒	2
10	1601	Screw for 68237	糸調子台止ネジ	2
11	68410	Thread Tension Support	糸調子台	1
12	68233	Thread Tension Support Bracket	糸調子台ブラケット	2
13	4552	Screw for 68233, 68259	止ネジ	4
14	482	Pin for 68235	糸緩メ軸バネ掛ケピン	1
15	68235	Tension Release Shaft Spring	糸緩メ軸バネ	1
16	68234	Tension Release Shaft	糸緩メ軸	1
17	485	Nut for 68244, 68243, 68245	ナット	6
18	68273	Tension Spring Bushing	糸調子ナット廻り止メ	6
19	68244	Looper Thread Tension Spring	ルーバ糸調子バネ	1
20	68243	Ornamental Thread Tension Spring	飾り糸調子バネ	1
21	68245	Needle Thread Tension Spring	針糸調子バネ	4
22	68413	Tension Release Pin Bushing	糸緩メピンブッシュ	7
23	31111	Thread Tension Disc	糸調子皿	12
24	68411	Thread Tension Disc Eyelet	調子台糸道	3
25	4206	Tension Post	糸調子棒	6
26	68412	Tension Release Pin	糸緩メピン	7
27	68355	SP Unit, Complete Set	SP装置(組)	1
28	68350	Oil Cup Lid	SPタンク蓋	1
29	693	Pin for 68350	SPタンク蓋ヒンジピン	1
30	68353	SP Felt	SPフェルト	4
31	68352	SP Felt Stay	SPフェルト受ケ	4
32		Oil Wick	油芯(毛糸)	4
33	68349	SP Oil Cup	SPタンク	1
34	68351	SP Oil Cup Support	SPタンク取付板	1
35	7619	Screw for 68349	SPタンク止ネジ	2
36	68259	Ornamental Thread Take-up Eyelet Holder	飾り糸調子カム糸道ホルダ	1
37	68260	Ornamental Thread Take-up Eyelet	飾り糸調子カム糸道	1
38	4180	Screw for 68260	飾り糸調子カム糸道止ネジ	1
39	68258	Looper Thread Take-up Guide	ルーバ糸調子カム糸案内	1
40	1222	Screw for 68258, 68269	止ネジ	4
41	68256	Looper Thread Take-up Eyelet (Front)	ルーバ糸調子カム糸道(前)	1
42	68257	Looper Thread Take-up Eyelet (Rear)	ルーバ糸調子カム糸道(後)	1
43	4245	Screw for 68256, 68257, 68250	止ネジ	4
44	68255	Eyelet Supporting Plate	カム糸道取付板	1
45	68262	Looper Thread Guard	ルーバ糸ガード	1
46	32339	Ornamental Thread Pipe	飾り糸道パイプ	1
47	68261	Looper Thread Guide Wire (Upper)	ルーバ糸ガイドワイヤ(上)	1
48	68269	Needle Thread Strike-off Pin Holder Bracket	針糸受ケホルダ取付台	1
49	68270	Needle Thread Strike-off Pin	針糸受ケ	4
50	4197	Screw for 68270	針糸受ケ止ネジ	4
51	68324	Needle Thread Strike-off Pin Holder	針糸受ケホルダ	1
52	4187	Screw for 68324	針糸受ケホルダ止ネジ	2
53	68242	Needle Thread Guide Wire	針糸ガイドワイヤ	1
54	68267	Head Cover Thread Eyelet	ヘッドカバー糸道	1
55	9730	Screw for 68267	ヘッドカバー糸道止ネジ	1
56	68246	Needle Thread Eyelet Holder	フレーム針糸道ホルダ	1
57	7311	Screw for 68246	フレーム針糸道ホルダ止ネジ	1
58	68249	Needle Thread Eyelet	フレーム針糸道	4
59	68250	Stitch Unlocker Mounting Bracket	針糸道バネブラケット	1
60	4191	Screw for 68251	針糸道バネ止ネジ	1
61	1196	Screw for 68251, 68252	止ネジ	2
62	68251	Stitch Unlocking Spring	針糸道バネ	1
63	68252	Stitch Unlocking Spring Holder	針糸道バネホルダ	1
64	4321	Screw for 68235	バネ掛ケネジ	1
65	3312	Screw for 68249	フレーム糸道止ネジ	4

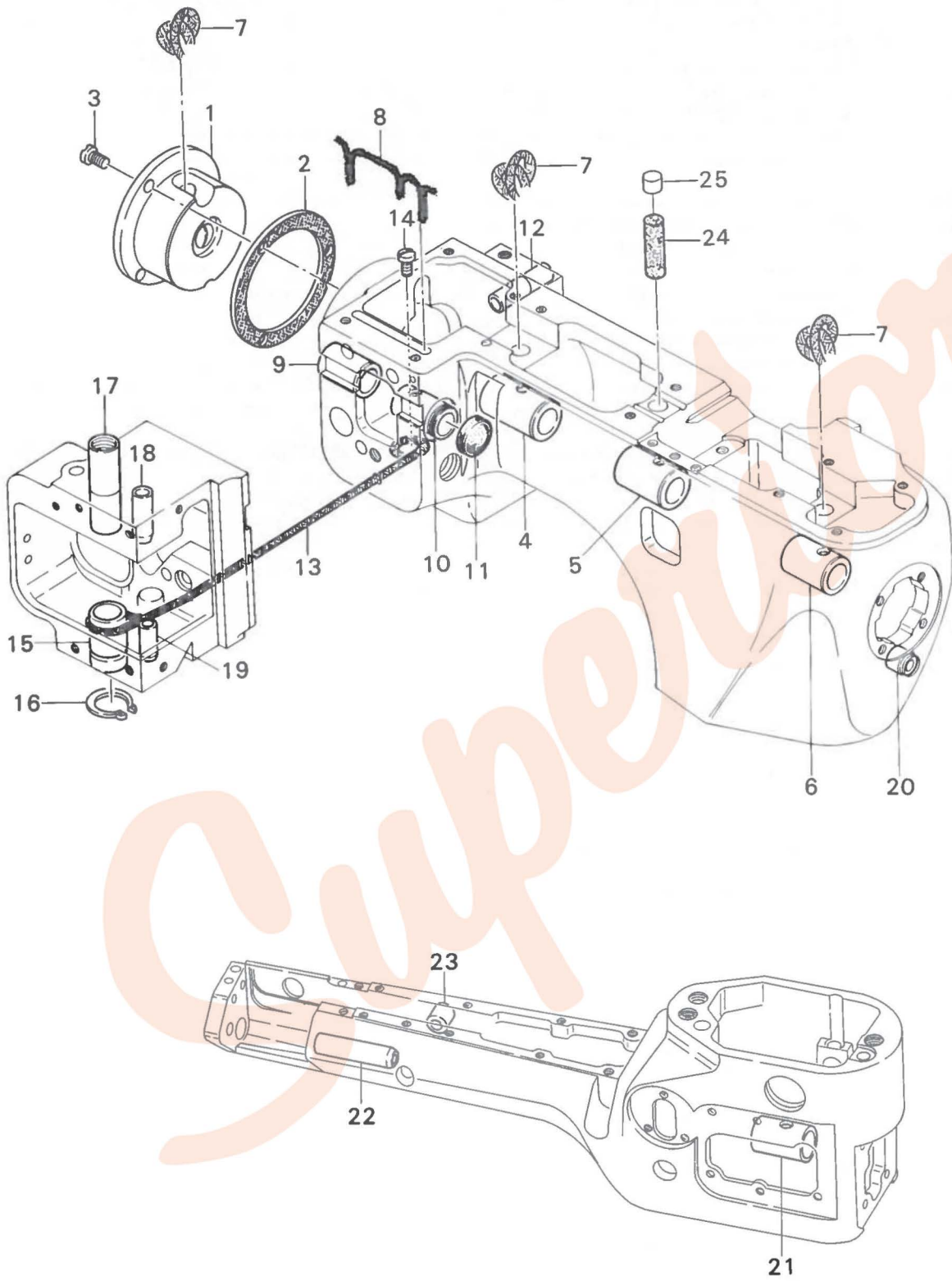

Ref. No.	Parts No.	Description	品名	Amt. Req.
1	68044	Bushing Housing Unit	ブッシュハウジング(組)	1
2	68047	Bushing Housing Gasket	ブッシュハウジングパッキン	1
3	4202	Screw for 68044	ブッシュハウジング止ネジ	3
4	68048	Crankshaft Bushing (Front)	クランクシャフトブッシュ(前)	1
5	68049	Main Shaft Bushing (Rear)	メインシャフトブッシュ(後)	1
6	68050	Main Shaft Bushing (Front)	メインシャフトブッシュ(前)	1
7	—	Oil Wick for 68044, 68048, 68050 (300mm)	油芯(毛糸)	3
8	463	Oil Wick for 68169, 68168	油芯	1
9	68169	Knife Driving Lever Bushing (Rear)	上メスレバーブッシュ(後)	1
10	68168	Knife Driving Lever Bushing (Front)	上メスレバーブッシュ(前)	1
11	68170	Bushing Cap	ブッシュキャップ	1
12	68139	Presser Foot Lifter Stop Plunger Bushing	ストッププランジャブッシュ	1
13	464	Oil Wick for 68152 (320mm)	油芯	1
14	4440	Screw for Oil Wick	油芯止ネジ	1
15	68152	Thread Carrier and Hook Sleeve Bushing	キャリア・フックスリーブブッシュ	1
16	68153	Retaining Ring	止メ輪	1
17	68131	Presser Bar Bushing	押工棒ブッシュ	1
18	68055	Needle Bar Bushing (Upper)	針棒ブッシュ(上)	1
19	68056	Needle Bar Bushing (Lower)	針棒ブッシュ(下)	1
20	68230	Looper Driving Lever Shaft Bushing	ルーバレバー軸ブッシュ	1
21	68214	Looper Rocker Shaft Bushing (Front)	ルーバ軸ブッシュ(前)	1
22	68215	Looper Rocker Shaft Bushing (Rear)	ルーバ軸ブッシュ(後)	1
23	68108	Feed Bar Eccentric Pin Bushing	送り台エキセンピンブッシュ	1
24	390	Oil Wick for 68049	油芯	1
25	68035	Seal Plug for Machine Frame	詰栓	1

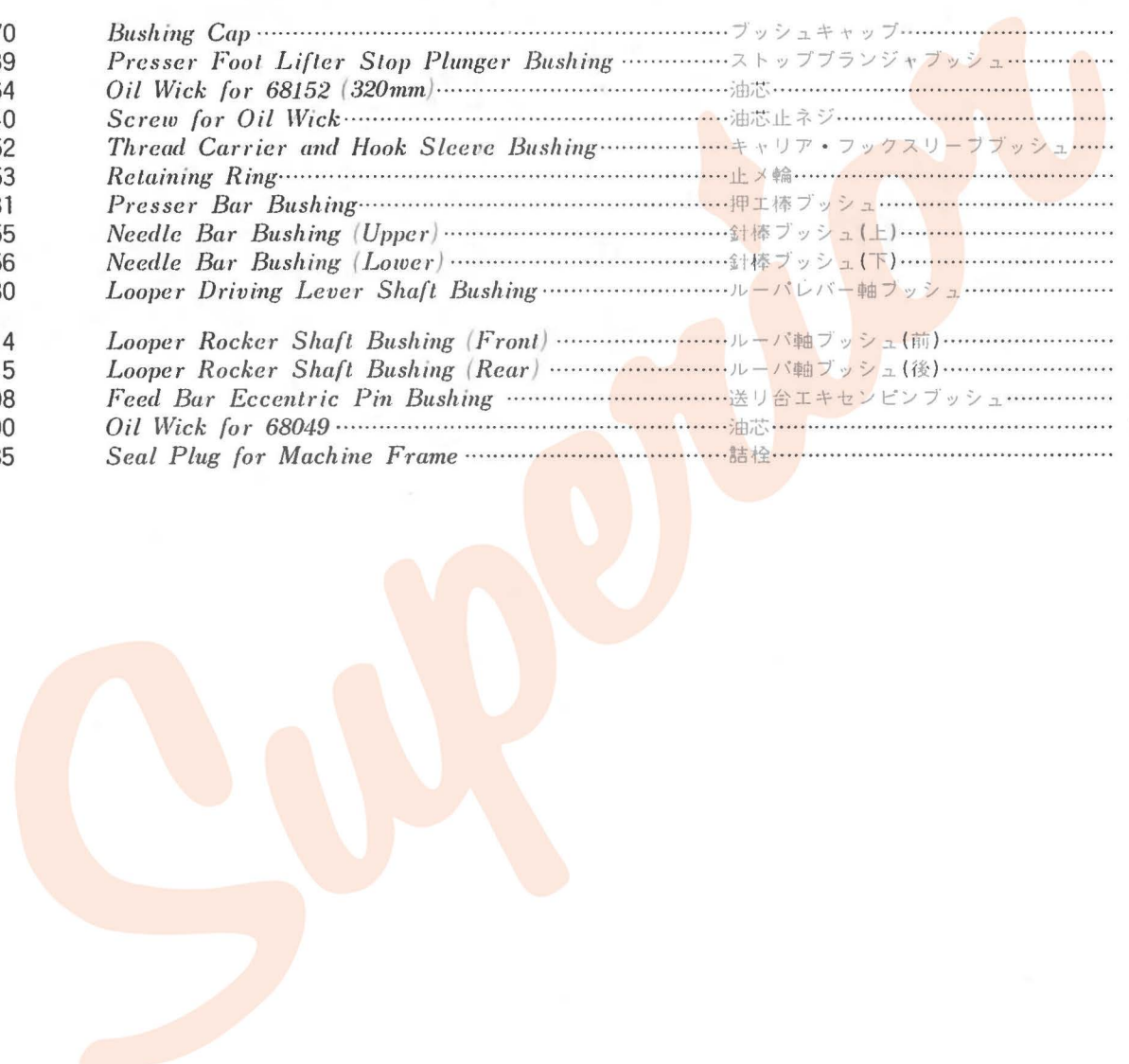

5

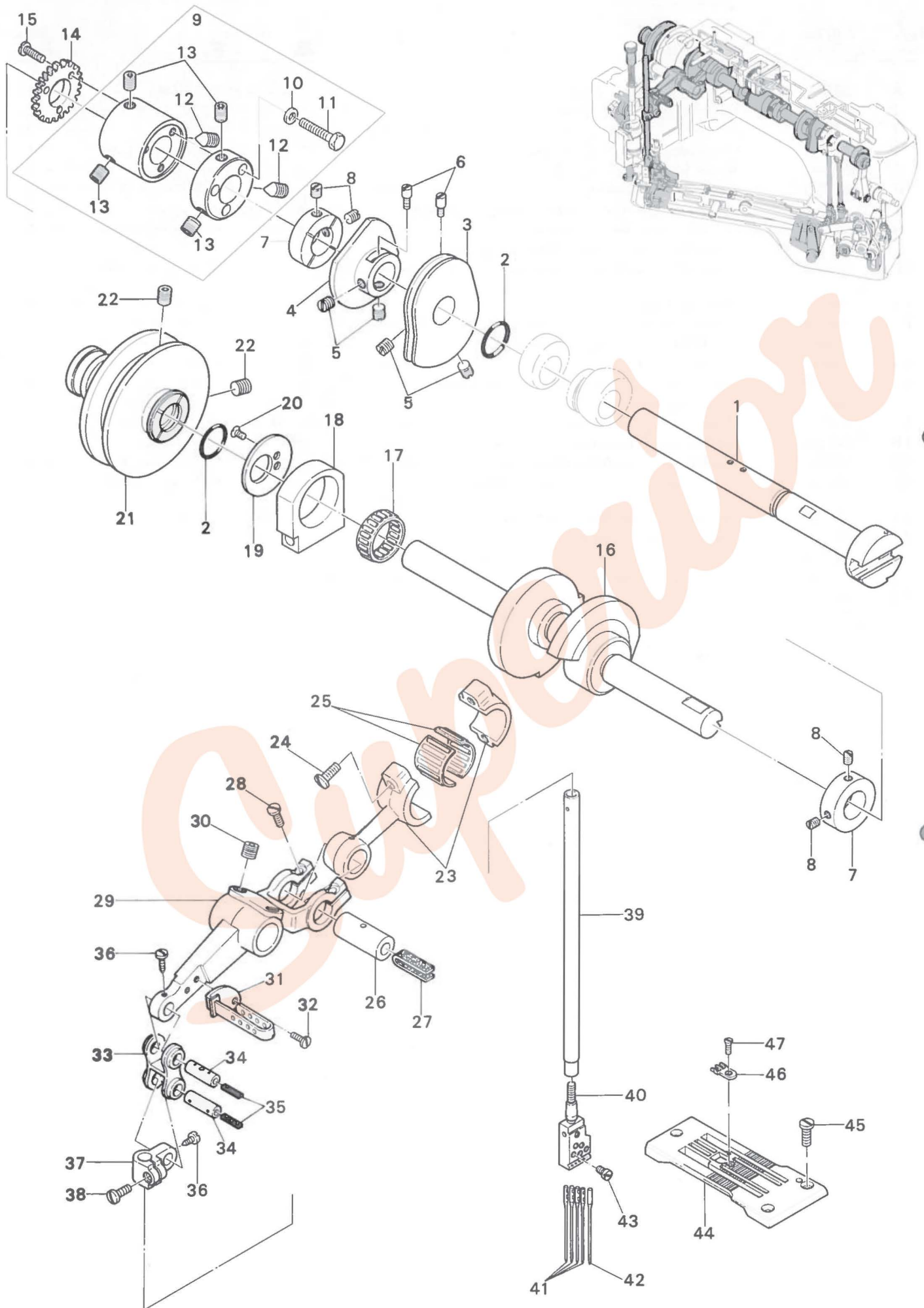

Ref. No.	Parts No.	Description	品名	Amt. Req.
1	68039	Main Shaft	メインシャフト	1
2	68033	Oil Seal for 68039	○リング	2
3	68253	Looper Thread Take-up	ルーバ糸調子カム	1
4	68254	Ornamental Thread Take-up	飾り糸調子カム	1
5	8047	Screw for 68253, 68254	止ネジ	4
6	3410	Positioning Screw for 68253, 68254	位置決メネジ	2
7	68043	Crankshaft Thrust Collar	クランクシャフトスラストカラー	2
8	3434	Screw for 68043	クランクシャフトスラストカラー止ネジ	4
9	68040	Main Shaft Coupling, Complete Set	メインシャフトカップリング(組)	1
10	530	Washer for 68040	ワッシャー	3
11	4177	Screw for 68040	カップリング止ネジ	3
12	3649	Screw for 68040	カップリング決メネジ	2
13	3646	Screw for 68040	カップリング止ネジ	4
14	68276	Pump Driving Gear	ポンプ駆動ギア	1
15	4186	Screw for 68276	ポンプ駆動ギア止ネジ	3
16	68038	Crankshaft	クランクシャフト	1
17	68146	Needle Bearing for 68145	ニードルベアリング	1
18	68145	Thread Carrier and Hook Driving Rod (Right)	キャリア・フックロッド(右)	1
19	68147	Needle Bearing Retaining Plate	ニードルベアリング保持板	1
20	7619	Screw for 68147	ニードルベアリング保持板止ネジ	2
21	68037	Pulley	プーリ	1
22	4123	Screw for 68037	プーリ止ネジ	2
23	68060	Needle Bar Lever Connecting Rod	針棒ロッド	1
24	5070	Screw for 68060	針棒ロッドキャップ止ネジ	2
25	34406	Needle Bearing for 68060	ニードルベアリング	1
26	68059	Needle Bar Lever Connecting Rod Pin	針棒ロッドピン	1
27	203	Oil Wick for 68059	油芯	1
28	1170	Screw for 68059	針棒ロッドピン止ネジ	2
29	68058	Needle Bar Lever	針棒レバー	1
30	3635	Screw for 68058	針棒レバー止ネジ	2
31	68268	Needle Bar Lever Thread Eyelet	針棒レバー糸道	1
32	1222	Screw for 68268	針棒レバー糸道止ネジ	2
33	90321	Needle Bar Connecting Link	針棒リンク	1
34	90320	Needle Bar Connecting Link Pin	針棒リンクピン	2
35	278	Oil Wick for 90320	油芯	2
36	4313	Screw for 90320	針棒リンクピン止ネジ	2
37	68057	Needle Bar Connecting Bracket	針棒抱キ	1
38	4185	Screw for 68057	針棒抱キ止ネジ	1
39	68054	Needle Bar	針棒	1
40	68053	Needle Clamp	針止メ	1
41	—	Needle	針	4
42	—	Retainer	リティナ	1
43	4170	Screw for Needle and Retainer	針止ネジ	5
44	68061	Stitch Plate	針板	1
45	4185	Screw for 68061	針板止ネジ	3
46	68062	Stitch Plate Tongue	針板爪	1
47	4182	Screw for 68062	針板爪止ネジ	1

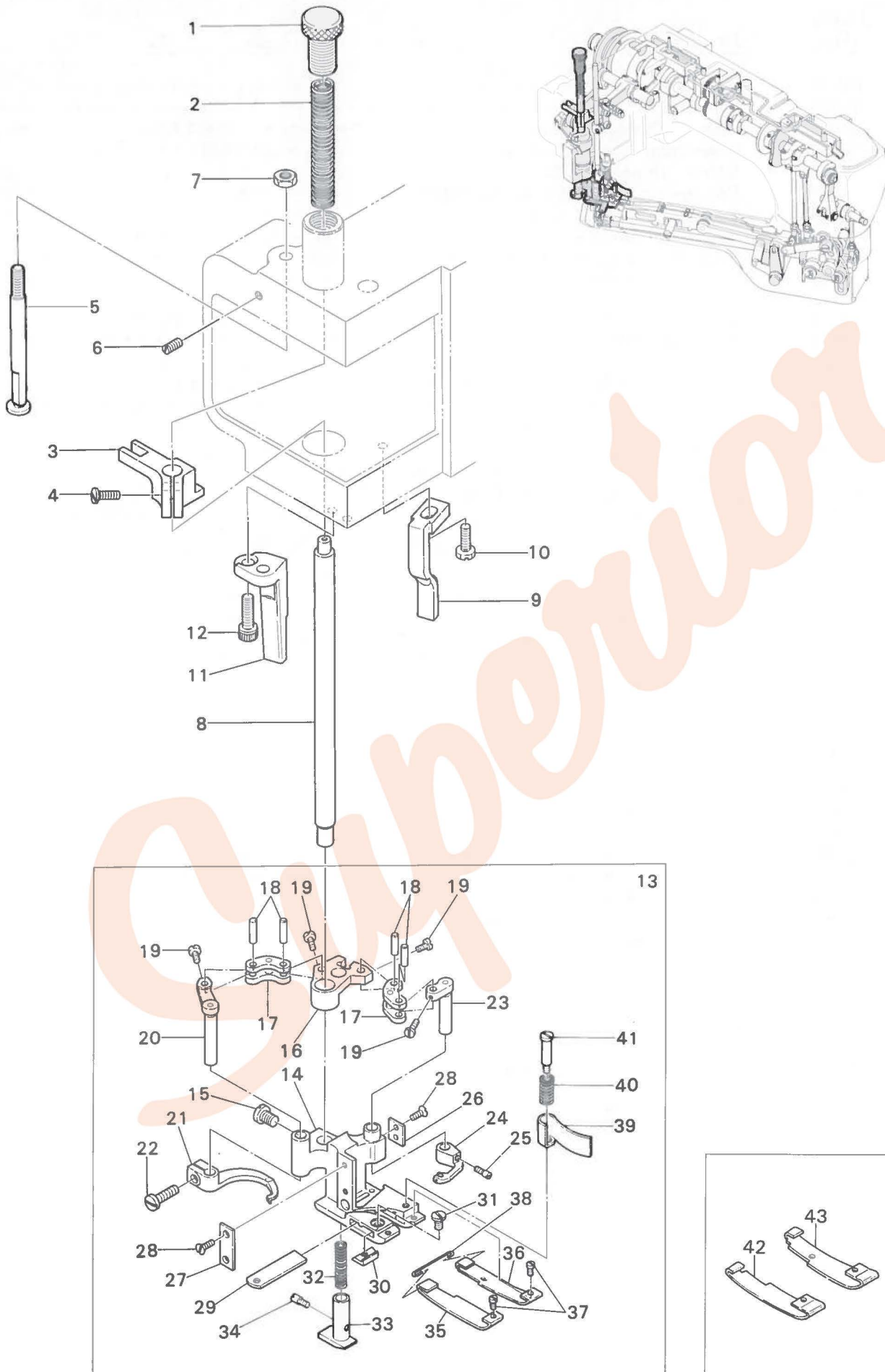

Ref. No.	Parts No.	Description	品名	Amt. Req.
1	4167	Adjusting Screw for 68132	押エバネ調節ネジ	1
2	68132	Presser Spring	押エバネ	1
3	68133	Presser Bar Connecting Bracket	押工棒抱キ	1
4	4437	Screw for 68133	押工棒抱キ止ネジ	1
5	68134	Presser Bar Guide	押工棒ガイド	1
6	9209	Screw for 68134	押工棒ガイド止ネジ	1
7	206	Nut for 68134	ナット	1
8	68130	Presser Bar	押工棒	1
9	68135	Presser Foot Guide (Right)	押エガイド(右)	1
10	4176	Screw for 68135	押エガイド(右)止ネジ	1
11	68136	Presser Foot Guide (Left)	押エガイド(左)	1
12	5650	Screw for 68136	押エガイド(左)止ネジ	2
13	68111	Presser Foot, Complete Set	押工(組)	1
14	68112	Presser Foot	押工	1
15	9853	Screw for 68112	押工止ネジ	1
16	68127	Thread Carrier and Hook Driving Segment	キャリア・フックセグメント	1
17	68128	Thread Carrier and Hook Driving Lever Link	キャリア・フックレバーリンク(組)	2
18	68129	Thread Carrier and Hook Driving Lever Link Pin	キャリア・フックレバーリンクピン	4
19	4172	Screw for 68129	キャリア・フックレバーリンクピン止ネジ	4
20	68126	Thread Hook Driving Lever	飾り糸フックレバー	1
21	68124	Ornamental Thread Hook	飾り糸フック	1
22	4185	Screw for 68124	飾り糸フック止ネジ	1
23	68125	Ornamental Thread Carrier Driving Lever	飾り糸キャリアレバー	1
24	68123	Ornamental Thread Carrier	飾り糸キャリア	1
25	4180	Screw for 68123	飾り糸キャリア止ネジ	1
26	68346	Presser Foot Attach Piece (Right)	押エガイド板(右)	1
27	68347	Presser Foot Attach Piece (Left)	押エガイド板(左)	1
28	4154	Screw for 68346, 68347	止ネジ	4
29	68121	Lower Knife	下メス	1
30	68122	Lower Knife Clamp	下メスクランプ	1
31	1227	Screw for 68122	下メスクランプ止ネジ	1
32	68117	Yielding Section Spring	小押エバネ	1
33	68116	Yielding Section	小押工	1
34	4180	Screw for 68116	小押工止ネジ	1
35	68118	Presser Foot Spring Plate (A) (Left)	押工板バネA(左)	1
36	68119	Presser Foot Spring Plate (A) (Right)	押工板バネA(右)	1
37	4173	Screw for 68118, 68119	止ネジ	2
38	68120	Spring Plate Holder	押工板バネホルダ	1
39	68187	Chip Guard	チップガード	1
40	68189	Chip Guard Spring	チップガードバネ	1
41	4166	Screw for 68187	チップガード止ネジ	1
42	68157	Presser Foot Spring Plate (B) (Left)	押工板バネ(B)(左)	1
43	68158	Presser Foot Spring Plate (B) (Right)	押工板バネ(B)(右)	1

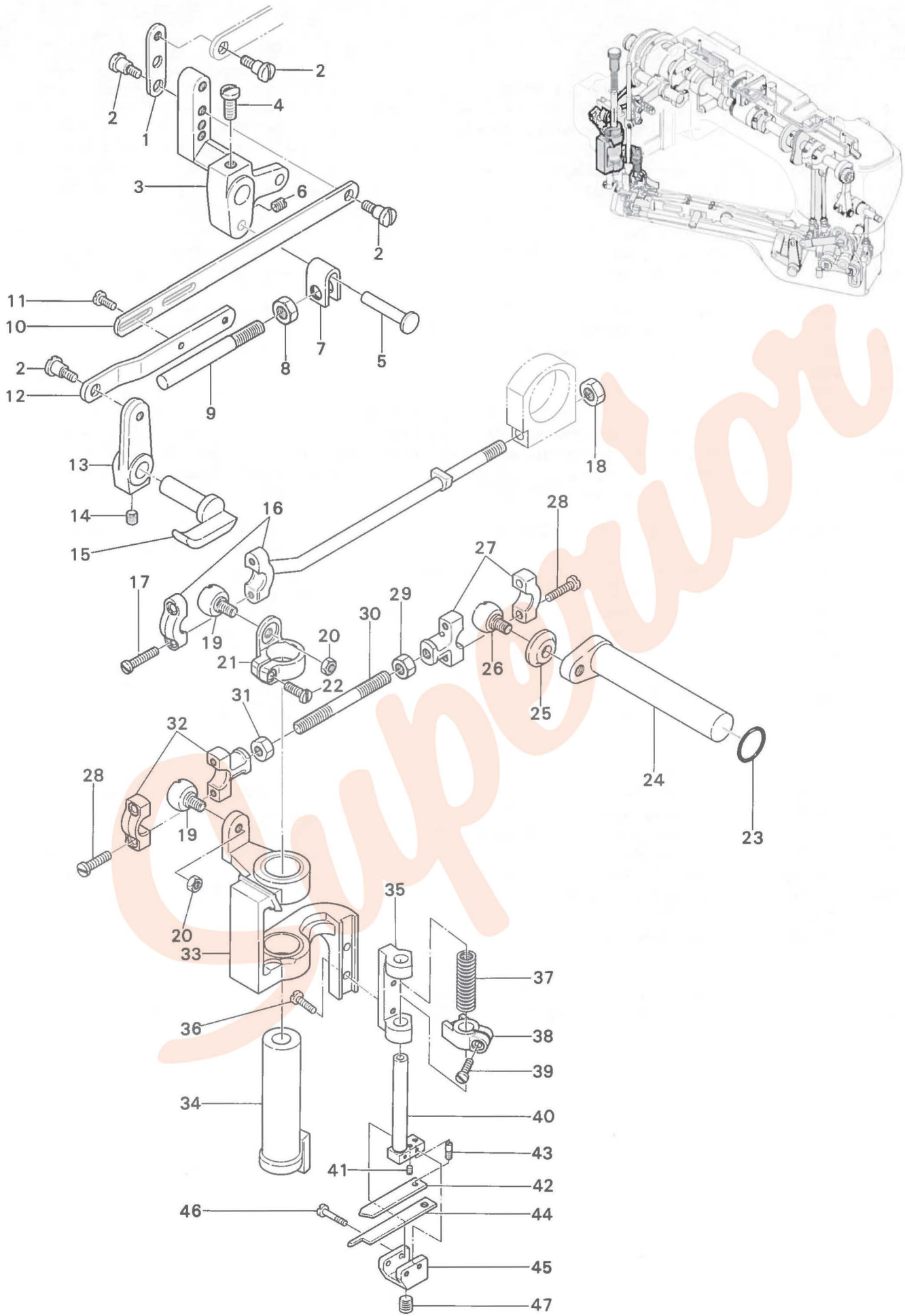



## フック機構

Ref. No.	Parts No.	Description	品名	Amt. Req.
1	68149	Presser Bar Lifter Lever Supplementary Plate	押工揚ゲレバー補助板	1
2	4189	Screw for 68149, 68142, 68154	止ネジ	4
3	68137	Presser Bar Lifter Lever (Large)	押工揚ゲレバー(大)	1
4	4552	Screw for 68137	押工揚ゲレバー(大)止ネジ	1
5	68141	Stop Plunger Segment Pin	ストッププランジャセグメントピン	1
6	3564	Screw for 68141	ストッププランジャセグメントピン止ネジ	1
7	68140	Stop Plunger Segment	ストッププランジャセグメント	1
8	363	Nut for 68138	ナット	1
9	68138	Presser Foot Lifter Stop Plunger	押工揚ゲストッププランジャ	1
10	68142	Presser Foot Lifter Lever Link (Long)	押工揚ゲリンク(長)	1
11	4358	Screw for 68142	押工揚ゲリンク(長)止ネジ	2
12	68154	Presser Foot Lifter Lever Link (Short)	押工揚ゲリンク(短)	1
13	68143	Presser Bar Lifter Lever (Small)	押工揚ゲレバー(小)	1
14	3653	Screw for 68143	押工揚ゲレバー(小)止ネジ	1
15	68144	Presser Bar Lifter Lever	押工揚ゲ	1
16	68148	Thread Carrier and Hook Driving Rod (Left)	キャリア・フックロッド(左)	1
17	1174	Screw for 68148	キャリア・フックロッド(左)止ネジ	2
18	471	Nut for 68148	ナット	1
19	68174	Ball (Left) for 68148, 68173	ロッド球(左)	2
20	347	Nut for 68174	ナット	2
21	68150	Thread Carrier and Hook Sleeve Lever	キャリア・フックスリーブレバー	1
22	7609	Screw for 68150	キャリア・フックスリーブレバー止ネジ	1
23	68033	Oil Seal for 68167	リング	1
24	68167	Knife Driving Lever	上メスレバー	1
25	68176	Steady Washer for 68172	上メスロッド(右)振れ止め	1
26	68171	Knife Driving Connection Ball (Right)	上メスロッド球(右)	1
27	68172	Knife Driving Connection (Right)	上メスロッド(右)	1
28	1170	Screw for 68172, 68173	上メスロッド(右)(左)止ネジ	4
29	356	Nut for 68175 (Left-handed Screw)	ナット(左ネジ)	1
30	68175	Knife Driving Connecting Rod	上メスロッド連結棒	2
31	355	Nut for 68175	ナット	1
32	68173	Knife Driving Connection (Left)	上メスロッド(左)	1
33	68178	Knife Holder Bracket Unit	上メスホルダブラケット(組)	1
34	68151	Thread Carrier and Hook Driving Sleeve	キャリア・フックスリーブ	1
35	68348	Knife Holder Shank Support	上メスホルダシャンク台	1
36	1175	Screw for 68348	上メスホルダシャンク台止ネジ	2
37	68181	Knife Holder Spring	上メスホルダバネ	1
38	68182	Knife Holder Guide Collar	上メスホルダガイドカラー	1
39	4185	Screw for 68182	上メスホルダガイドカラー止ネジ	1
40	68180	Knife Holder Shank	上メスホルダシャンク	1
41	4181	Screw for 68180	上メスホルダシャンク止ネジ	1
42	68185	Knife Support	上メスサポート	1
43	4179	Screw for 68185	上メスサポート止ネジ	1
44	68184	Upper Knife	上メス	1
45	68183	Knife Holder	上メスホルダ	1
46	4171	Screw for 68183	上メスホルダ止ネジ	2
47	3635	Screw for 68184	上メス止ネジ	1

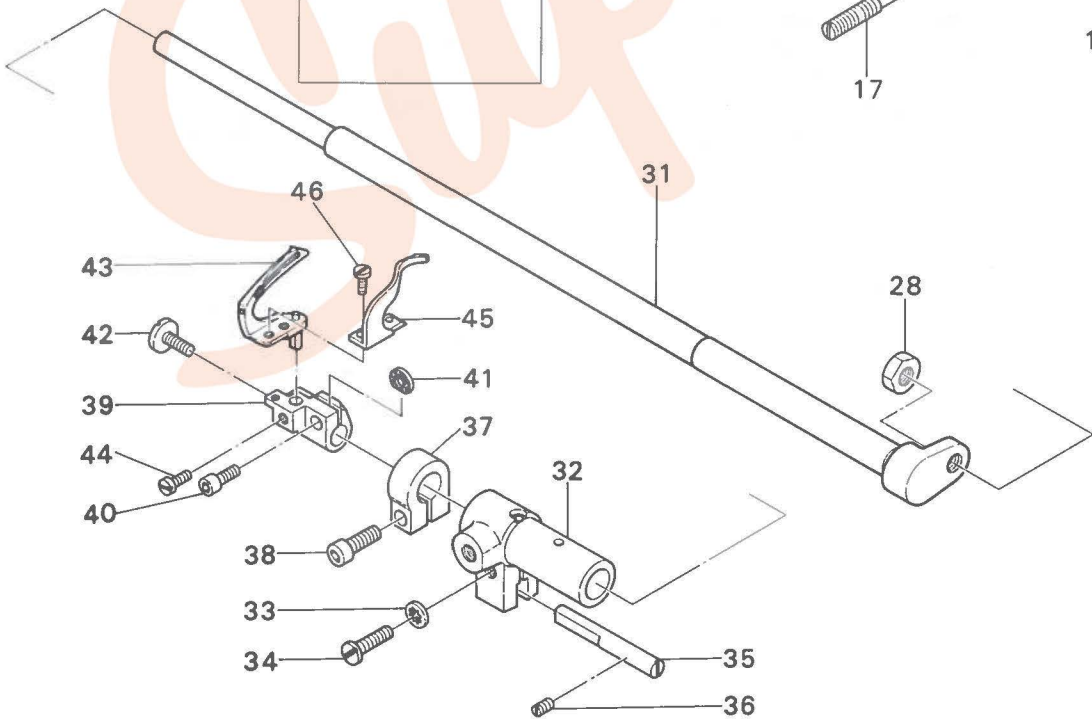
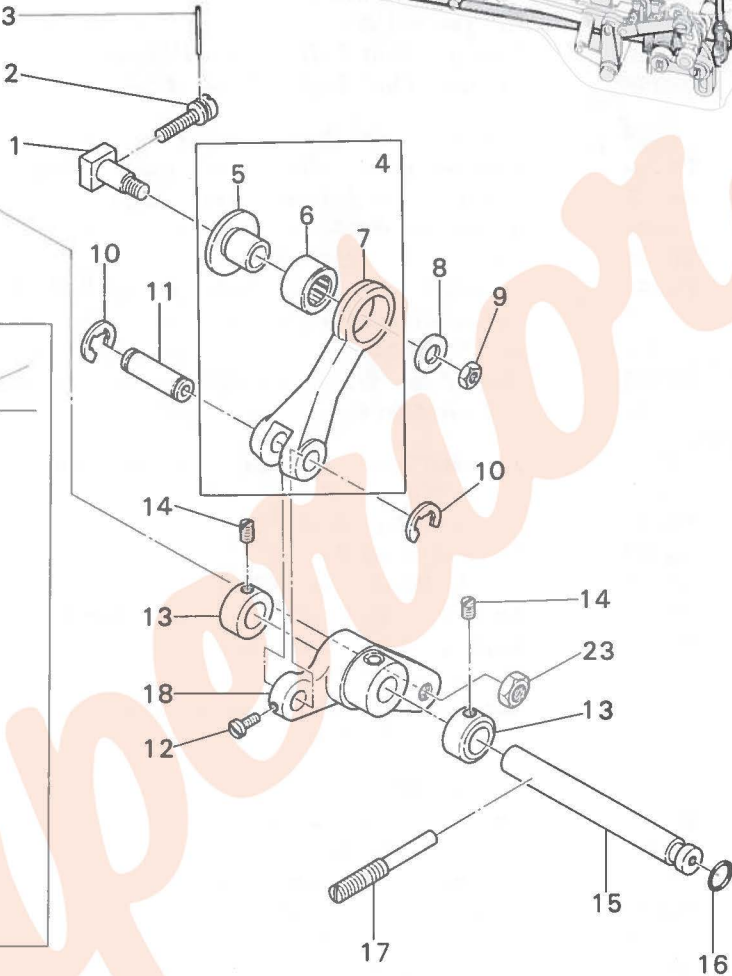
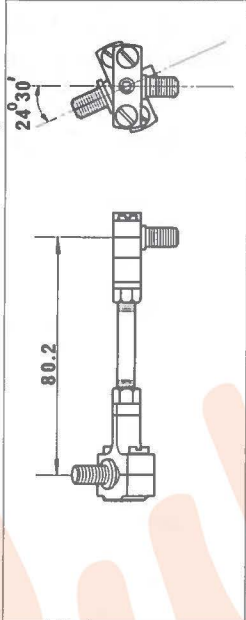
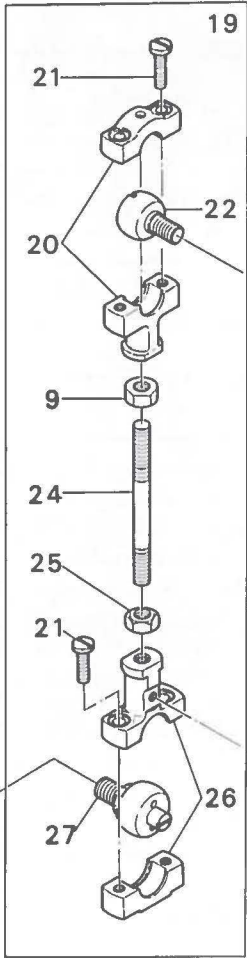
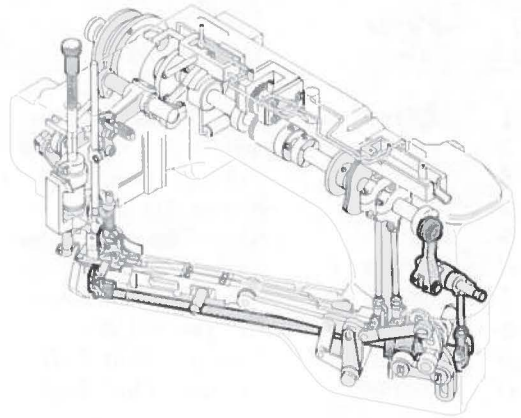

Ref. No.	Parts No.	Description	品名	Amt. Req.
1	68197	Looper Driving Crank Pin	ルーバクランクピン	1
2	4165	Screw for 68197	ルーバクランクピン止ネジ	1
3	477	Roll Pin for Main Shaft	ピン	1
4	68201	Looper Lever Driving Rod, Complete Set	ルーバレバーロッド(組)	1
5	68200	Looper Lever Driving Rod Bushing	ルーバレバーロッドブッシュ	1
6	68199	Needle Bearing for 68198	ベアリング(GB-65)	1
7	68198	Looper Lever Driving Rod	ルーバレバーロッド	1
8	586	Washer for 68200	ワッシャ	1
9	356	Nut for 68200, 68175 (Left-handed Screw)	ナット	2
10	68202	Retaining Ring for 68205	止メ輪	2
11	68205	Looper Lever Driving Rod Pin	ルーバレバーロッドピン	1
12	1222	Screw for 68205	ルーバレバーロッドピン止ネジ	1
13	68207	Looper Lever Shaft Collar	ルーバレバー軸カラー	2
14	1457	Screw for 68207	ルーバレバー軸カラー止ネジ	2
15	68204	Looper Lever Shaft	ルーバレバー軸	1
16	68206	Oil Seal for 68204	オリング	1
17	4164	Screw for 68204	ルーバレバー軸止ネジ	1
18	68203	Looper Lever	ルーバレバー	1
19	68208	Looper Driving Connecting Rod, Complete Set	ルーバロッド(組)	1
20	68209	Looper Driving Connection (Upper)	ルーバロッド(上)	1
21	1170	Screw for 68209, 68210	ルーバロッド止ネジ	4
22	68171	Looper Driving Connection Ball (Upper)	ルーバロッド球(上)	1
23	470	Nut for 68171	ナット	1
24	68175	Looper Driving Connecting Rod	ルーバロッド連結棒	1
25	355	Nut for 68175	ナット	1
26	68210	Looper Driving Connection (Lower)	ルーバロッド(下)	1
27	68212	Looper Driving Connection Ball (Lower)	ルーバロッド球(下)	1
28	306	Nut for 68212	ナット	1
29	68069	Steady Fork for 68210	ルーバロッド(下)振れ止メ	1
30	7609	Screw for 68069	ルーバロッド(下)振れ止メ止ネジ	1
31	68213	Looper Rocker Shaft	ルーバ軸	1
32	68222	Looper Rocker Shaft Sleeve	ルーバ軸スリーブ	1
33	548	Washer for 68222	ワッシャ	1
34	4352	Screw for 68222	ルーバ軸スリーブ止ネジ	1
35	68223	Looper Rocker Shaft Sleeve Guide	ルーバ軸スリーブガイド	1
36	3473	Screw for 68223	ルーバ軸スリーブガイド止ネジ	1
37	68224	Looper Rocker Shaft Collar	ルーバ軸カラー	1
38	5550	Screw for 68224	ルーバ軸カラー止ネジ	1
39	68216	Looper Holder	ルーバ台	1
40	5040	Screw for 68216	ルーバ台止ネジ	1
41	489	Packing for 68216	パッキン	1
42	4169	Adjusting Screw for 68216	ルーバ台調節ネジ	1
43	68217	Looper	ルーバ	1
44	1208	Screw for 68217	ルーバ止ネジ	1
45	68218	Needle Guard (Front)	針受ケ(前)	1
46	4284	Screw for 68218	針受ケ(前)止ネジ	2

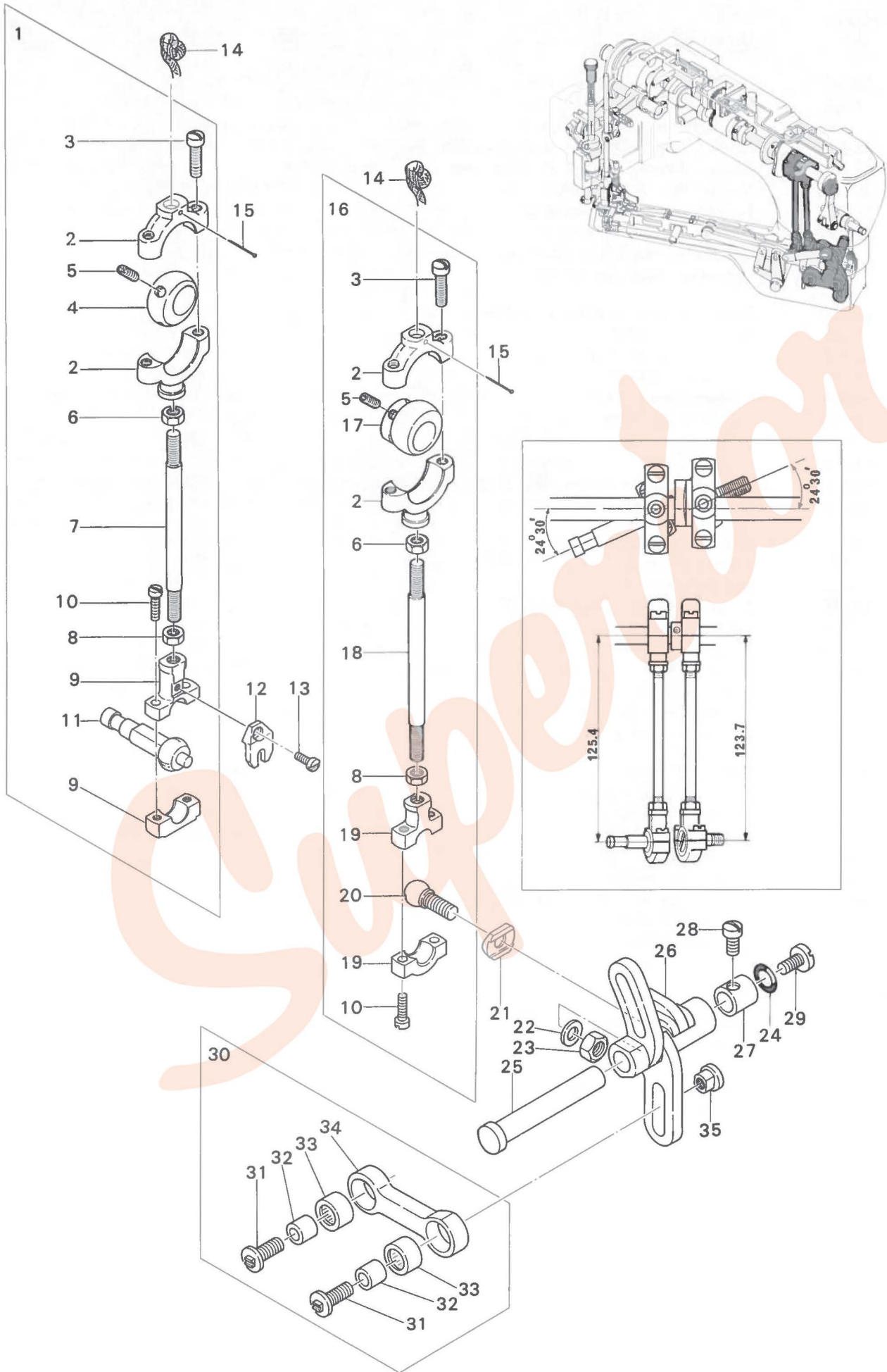

Ref. No.	Parts No.	Description	品名	Amt. Req.
1	68063	Feed Lift Eccentric, Complete Set	送り上下ロッド(組)	1
2	68065	Feed Lift Connection (Upper)	送り上下ロッド(上)	2
3	4441	Screw for 68065	送り上下ロッド(上)止ネジ	4
4	68064	Feed Lift Eccentric Ball	送り上下球エキセン	1
5	3638	Screw for 68064, 68071	止ネジ	4
6	356	Nut for 68066, 68073 (Left-handed Screw)	ナット	2
7	68066	Feed Lift Eccentric Connecting Rod	送り上下ロッド連結棒	1
8	355	Nut for 68066, 68073	ナット	2
9	68210	Feed Lift Connection (Lower)	送り上下ロッド(下)	1
10	1170	Screw for 68210, 68074	止ネジ	4
11	68068	Feed Lift Connection Ball	送り上下ロッド球	1
12	68069	Steady Fork for 68210	送り上下ロッド(下)振レ止メ	1
13	7609	Screw for 68069	送り上下ロッド(下)振レ止メ止ネジ	1
14		Oil Wick for 68065 (150mm)	油芯(毛糸)	2
15	755	Pin for Oil Wick	油芯止ピン	2
16	68070	Feed Drive Eccentric, Complete Set	送リ前後ロッド(組)	1
17	68071	Feed Drive Eccentric Ball	送リ前後球エキセン	1
18	68073	Feed Drive Eccentric Connecting Rod	送リ前後ロッド連結棒	1
19	68074	Feed Drive Connection (Lower)	送リ前後ロッド(下)	1
20	68075	Feed Drive Connection Ball	送リ前後ロッド球	1
21	68076	Steady Washer for 68074	送リ前後ロッド(下)振レ止メ	1
22	474	Washer for 68075	ワッシャ	1
23	306	Nut for 68075	ナット	1
24	68079	Oil Seal for 68345	オリング	1
25	68345	Feed Drive Shaft	送リレバー軸	1
26	68077	Feed Drive and Looper Avoid Lever	送リレバー	1
27	68080	Feed Drive Shaft Bushing	送リレバー軸ブッシュ	1
28	5047	Screw for 68345	送リレバー軸止ネジ	1
29	4203	Screw for 68079	オリング止ネジ	1
30	68219	Looper Avoid Connecting Rod, Complete Set	ルーバ前後ロッド(組)	1
31	4162	Screw for 68221	ルーバ前後ロッドブッシュ止ネジ	2
32	68221	Looper Avoid Connecting Rod Bushing	ルーバ前後ロッドブッシュ	2
33	68199	Needle Bearing for 68220	ベアリング(GB-65)	2
34	68220	Looper Avoid Connecting Rod	ルーバ前後ロッド	1
35	68228	Looper Avoid Adjusting Nut	ルーバ前後量調節ナット	1

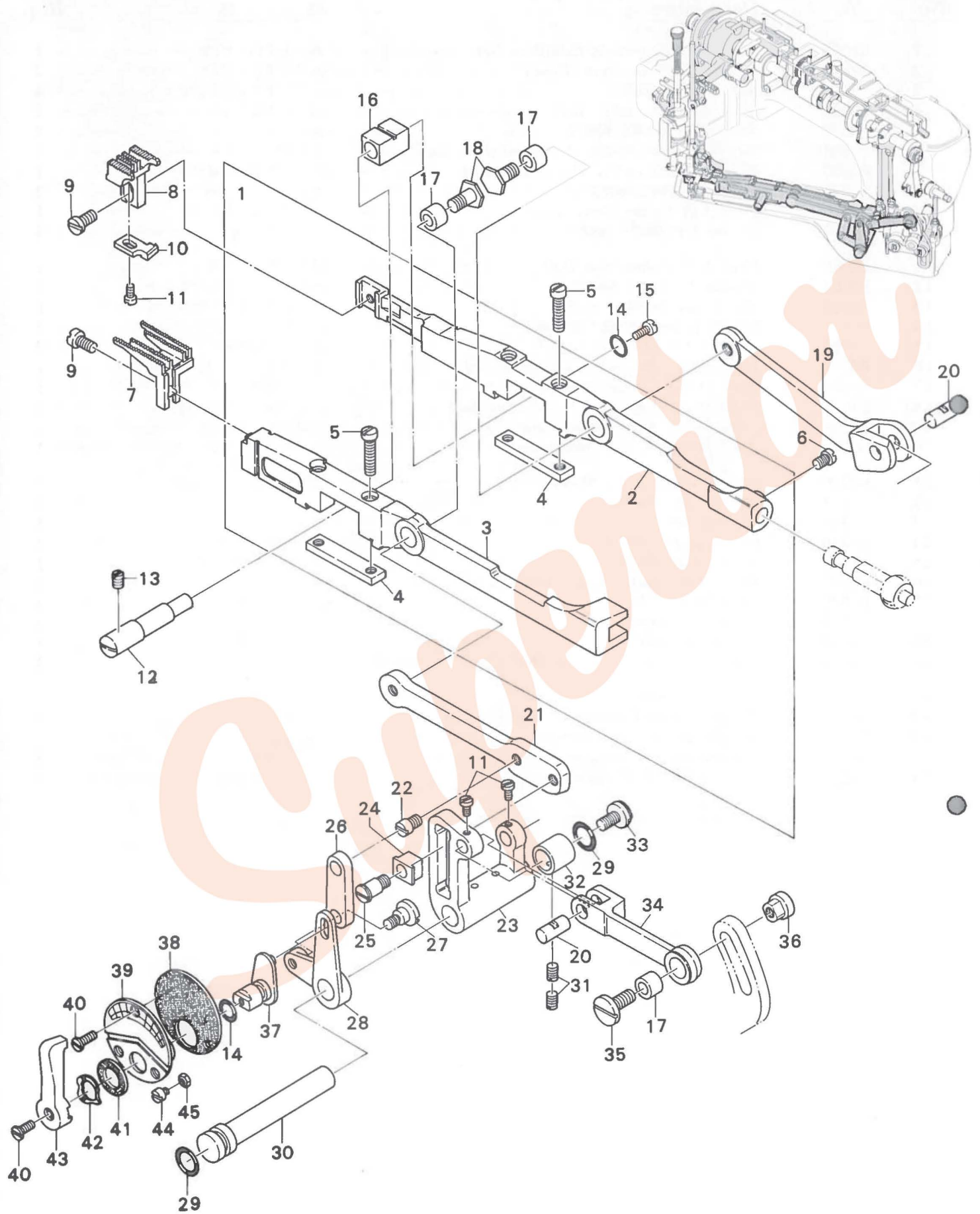

Ref. No.	Parts No.	Description	品名	Amt. Req.
1	68106	Feed Bar, Complete Set	送り台(組)	1
2	68092	Main Feed Bar	後送り台	1
3	68091	Differential Feed Bar	前送り台	1
4	68093	Feed Bar Plate	送り台補助板	2
5	5004	Screw for 68093	送り台補助板止ネジ	4
6	9604	Screw for 68068	送り上下ロッド球止ネジ	1
7	68095	Differential Feed Dog	前送り	1
8	68096	Main Feed Dog	後送り	1
9	4440	Screw for 68095, 68096	止ネジ	2
10	68097	Needle Guard (Rear)	針受ケ(後)	1
11	1222	Screw for 68097, 68084	止ネジ	3
12	68089	Feed Bar Eccentric Pin	送り台エキセンピン	1
13	3434	Screw for 68089	送り台エキセンピン止ネジ	1
14	20472	Oil Seal for 68089, 68101	リング	2
15	4321	Screw for 20472	リング止ネジ	1
16	68090	Feed Bar Slide Block	角駒	1
17	68083	Feed Rocker Link Bushing	送りロックリンクブッシュ	3
18	4178	Screw for 68083	送りロックリンクブッシュ止ネジ	2
19	68088	Main Feed Bar Driving Link	後送りリンク	1
20	68084	Feed Rocker Link Pin	送りロックリンクピン	2
21	68086	Differential Feed Bar Driving Link	前送りリンク	1
22	4163	Screw for 68099	前送り調節レバーリンク止ネジ	1
23	68085	Feed Rocker	送りロック	1
24	68087	Differential Feed Bar Driving Link Slider	前送りリンクスライダ	1
25	4161	Screw for 68087	前送りリンクスライダ止ネジ	1
26	68099	Differential Feed Adjusting Link	前送り調節レバーリンク	1
27	4160	Screw for 68099	前送り調節レバーリンク止ネジ	1
28	68098	Differential Feed Adjusting Lever	前送り調節レバー	1
29	68079	Oil Seal for 68078	リング	2
30	68078	Feed Rocker Shaft	送りロック軸	1
31	3473	Screw for 68078	送りロック軸止ネジ	2
32	68080	Feed Rocker Shaft Bushing	送りロック軸ブッシュ	1
33	4203	Screw for 68079	リング止ネジ	1
34	68082	Feed Rocker Link	送りロックリンク	1
35	4551	Screw for 68083	送りロックリンクブッシュ止ネジ	1
36	68107	Feed Adjusting Nut	送り調節ナット	1
37	68101	Differential Feed Adjusting Lever	前送り調節中レバー	1
38	68104	Differential Feed Adjusting Dial Gasket	前送り調節ダイヤルバックン	1
39	68103	Differential Feed Adjusting Dial	前送り調節ダイヤル	1
40	7621	Screw for 68103, 68105	止ネジ	4
41	475	Washer for 68105	ワッシャ	1
42	487	Washer for 68105	ワッシャ	1
43	68105	Differential Feed Operating Lever	前送り調節外レバー	1
44	4168	Screw for 68105	前送り調節外レバー止ネジ	2
45	488	Nut for 4168	ナット	2

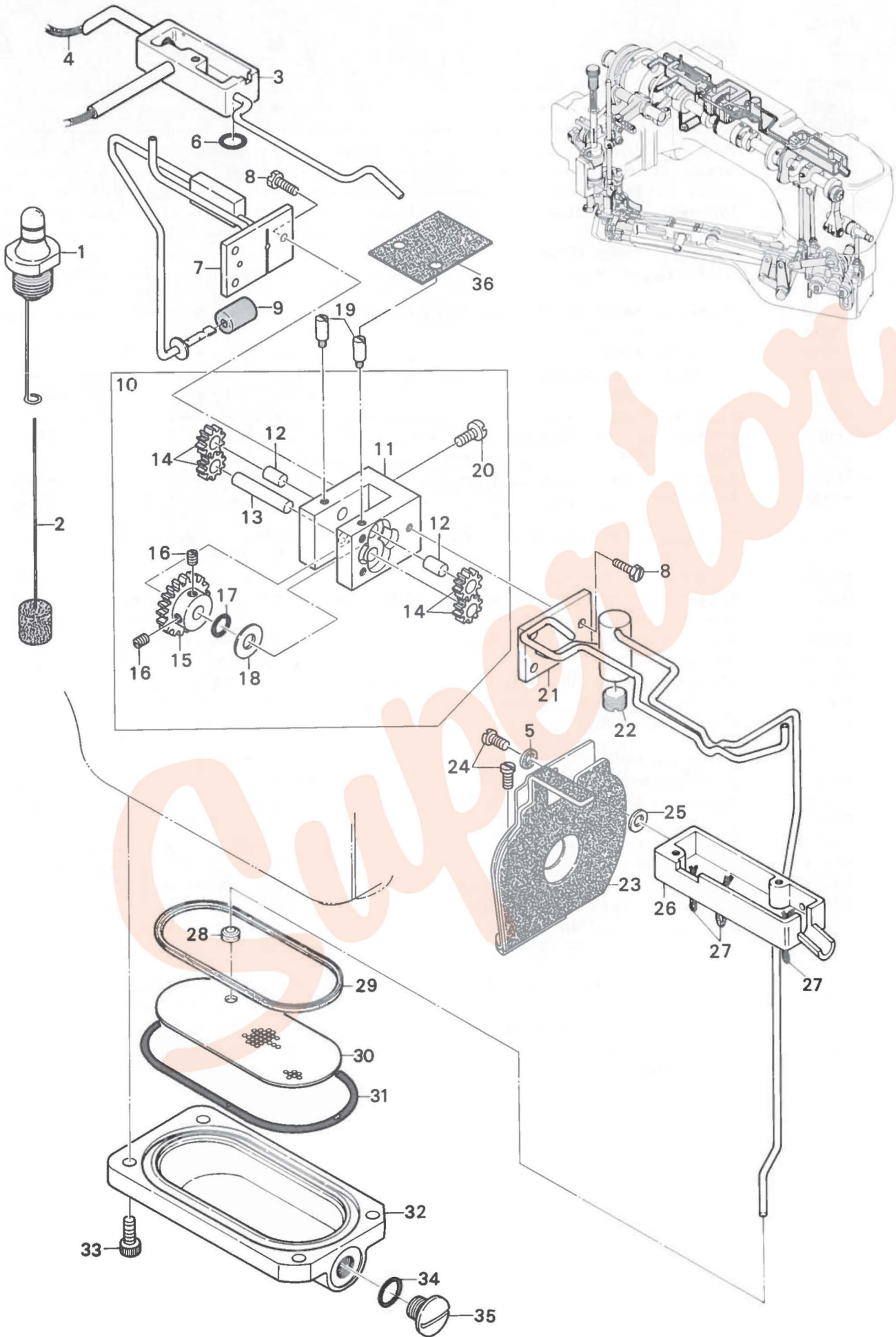



Ref. No.	Parts No.	Description	品名	Amt. Req.
1	68303	Crank Chamber Oil Gauge	クランク室オイルゲージ(組)	1
2	68304	Oil Height Indicator	油量指示棒	1
3	68296	Oil Receiver (Rear)	オイルタンク(後)	1
4	465	Oil Wick for 68296	油芯	1
5	550	Seal for 68298	パッキン	1
6	68079	Oil Seal for 68296	Oリング	1
7	68290	Pump Housing Cover Unit (Rear)	ポンプハウジングカバー(後)(組)	1
8	7605	Screw for 68290, 68282	ポンプハウジングカバー止ネジ	6
9	68294	In-take Filter	吸入フィルタ	1
10	68284	Pump, Complete Set	ポンプ(組)	1
11	68278	Pump Housing	ポンプハウジング	1
12	68281	Pump Gear Shaft (Short)	ポンプギアシャフト(短)	2
13	68280	Pump Gear Shaft (Long)	ポンプギアシャフト(長)	1
14	68279	Oil Pump Gear	ポンプギア	4
15	68277	Pump Driven Gear	ポンプ従動ギア	1
16	7650	Screw for 68277	ポンプ従動ギア止ネジ	2
17	20472	Oil Seal for 68277	Oリング	1
18	474	Washer for 68277	ワッシャ	1
19	4183	Screw for 68278	ポンプハウジング止ネジ	2
20	9150	Screw for 68278	ポンプハウジング止ネジ	2
21	68282	Pump Housing Cover Unit (Front)	ポンプハウジングカバー(前)(組)	1
22	4198	Screw for 68282	貯油管止ネジ	1
23	68298	Thread Take-up Oil Defense Unit	糸調子カム防油板	1
24	4353	Screw for 68298, 68287	止ネジ	2
25	532	Washer for 68298	ワッシャ	1
26	68287	Oil Receiver (Front)	オイルタンク(前)	1
27	—	Oil Wick for 68287	油芯(毛糸)	3
28	68344	Rubber Bushing	ゴムブッシュ	1
29	68343	Oil Filter Screen Rubber Seal	油受ケ濾過網パッキン	1
30	68342	Oil Filter Screen	油受ケ濾過網	1
31	68341	Oil Reservoir Rubber Seal	油受ケパッキン	1
32	68340	Oil Reservoir	油受ケ	1
33	5650	Screw for 68340	油受ケ止ネジ	4
34	32421	Drain Hole Seal	油受ケ油抜キOリング	1
35	5076	Drain Hole Screw	油抜キネジ	1
36	68289	Pump Housing Gasket	ポンプハウジングパッキン	1

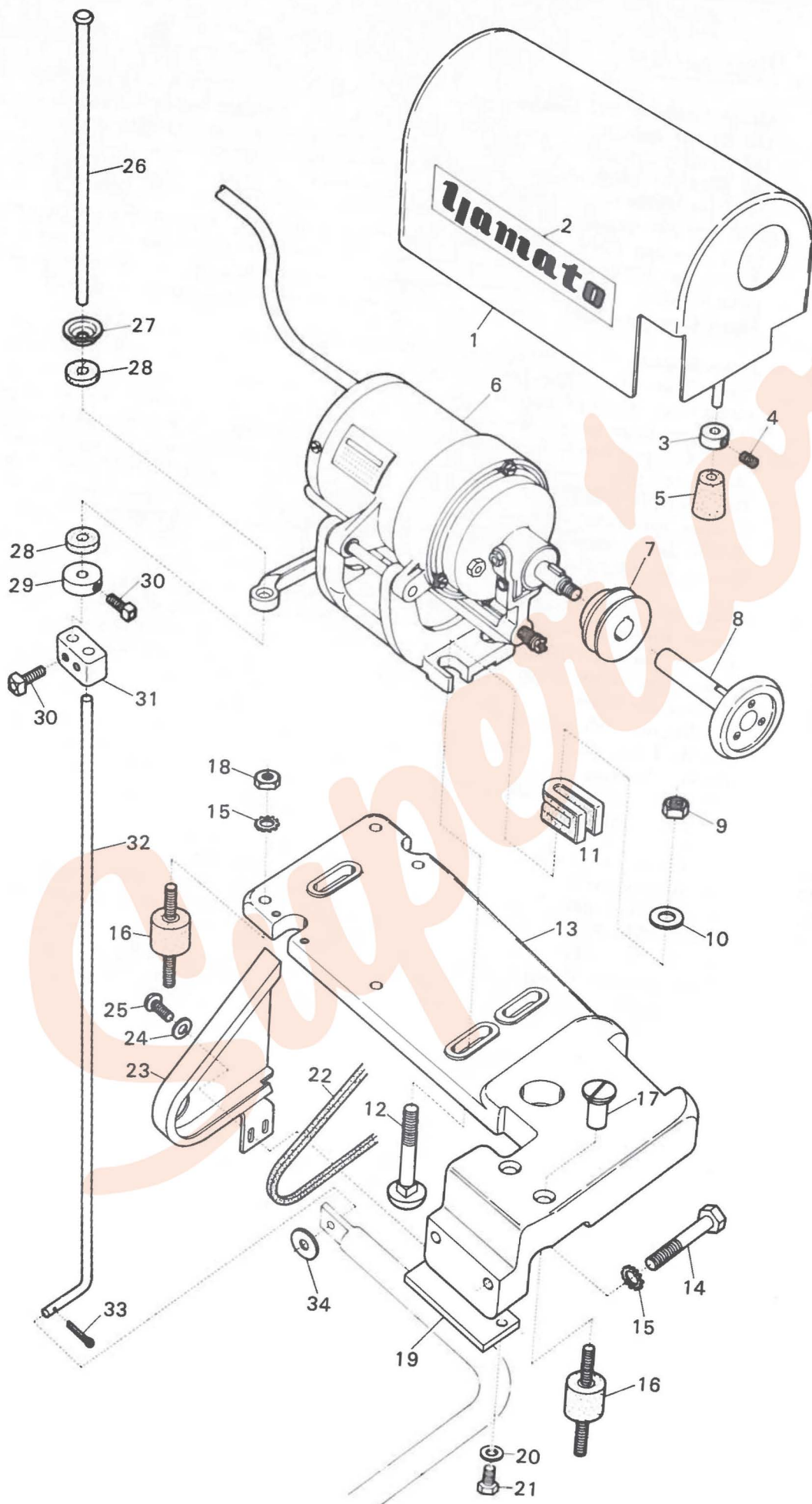

Ref. No.	Parts No.	Description	品名	Amt. Req.
1	68926	Motor Cover	モータカバー	1
2	68932	Brand Name Plate	銘板	1
3	68935	Cover Cushion Collar	カバークッションカラー	3
4	128	Screw for 68935	カバークッションカラー止ネジ	3
5	63009	Cover Cushion	カバークッション	3
6	68938	Motor Unit	モータ(組)	1
7	—	Motor Pulley	モータプーリ	1
8	68934	Handwheel	ハンドホイール	1
9	161	Nut for 68938	ナット	3
10	130	Washer for 68938	ワッシャ	3
11	68937	Motor Cushion	モータクッション	3
12	131	Screw for 68938	モータ(組)止ネジ	3
13	68902	Sewing Machine and Motor Supporting Plate	ミシン取付板	1
14	108	Screw for Sewing Machine	ミシン止ネジ	2
15	105	Toothed Washer for Sewing Machine, 68917	菊ワッシャ	6
16	68917	Supporting Plate Cushion	ミシン取付板クッション	6
17	107	Cap Nut for 68917	キャップナット	2
18	106	Nut for 68917	ナット	4
19	68936	Sewing Machine Setting Support	ミシン取付補助板	1
20	162	Washer for 68936	ワッシャ	2
21	129	Screw for 68936	ミシン取付補助板止ネジ	2
22	—	V-Belt	Vベルト	1
23	68930	Belt Cover	ベルトカバー	1
24	124	Washer for 68930	ワッシャ	2
25	123	Screw for 68930	ベルトカバー止ネジ	2
26	68922	Motor Lever Connecting Rod (Upper)	モータレバー連結棒(上)	1
27	166	Washer for 68922	ワッシャ	1
28	68921	Motor Lever Cushion	モータレバークッション	2
29	68920	Motor Lever Cushion Collar	モータレバークッションカラー	1
30	111	Screw for 68920, 68923	止ネジ	3
31	68923	Motor Lever Connecting Rod Joint	連結棒継手	1
32	68914	Motor Lever Connecting Rod (Lower)	モータレバー連結棒(下)	1
33	113	Cotter Pin	割ピン	1
34	112	Washer for 68914	ワッシャ	1

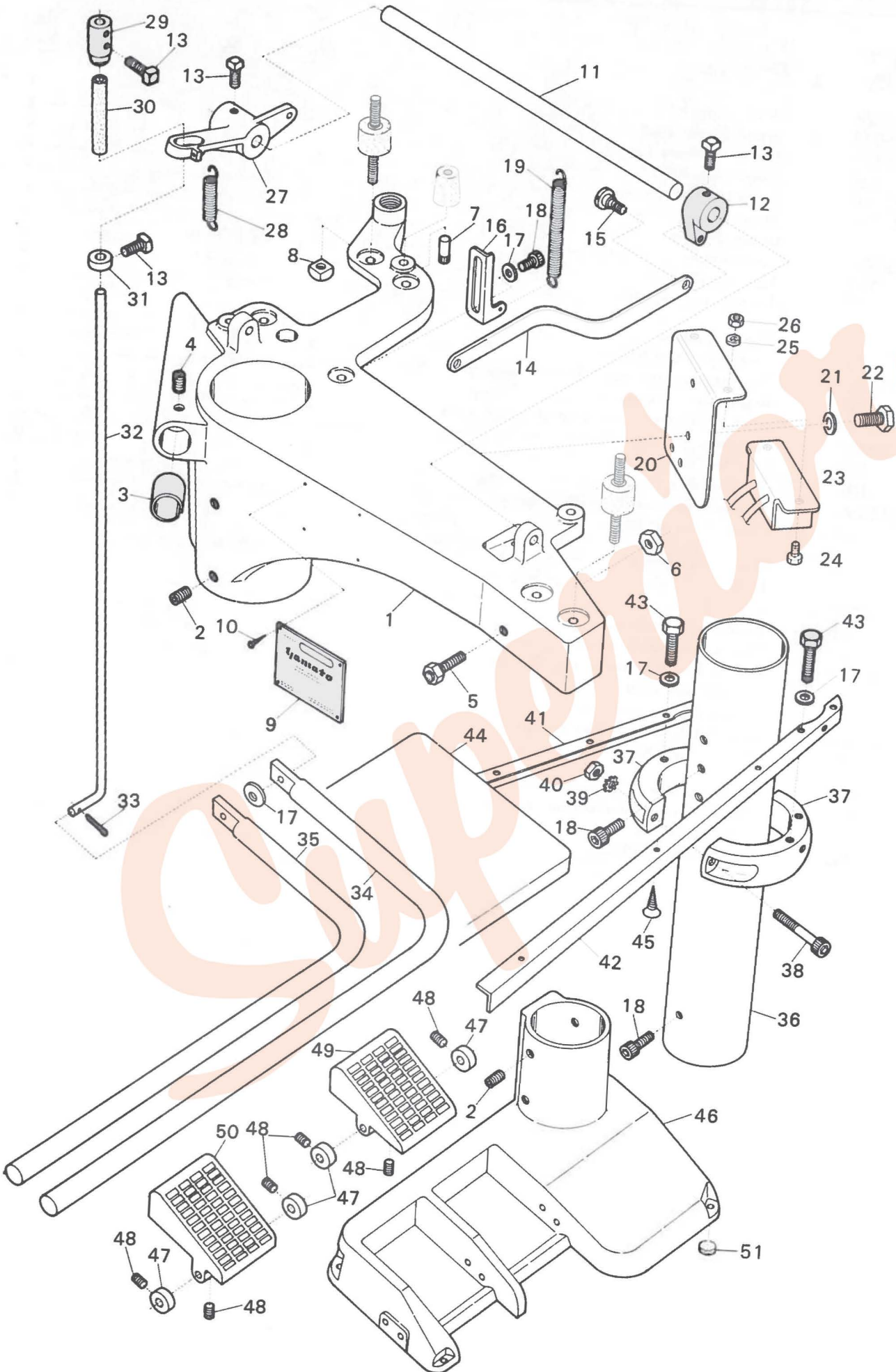

Ref. No.	Parts No.	Description	品名	Amt. Req.
1	68901	Sewing Machine Support Bracket	ミシン取付板保持台	1
2	102	Screw for 68905	コラム止ネジ	8
3	68925	Suction Pipe Holder	吸込管ホルダ	1
4	116	Screw for 68925	吸込管ホルダ止ネジ	1
5	103	Bolt for 68902 (with Rubber Cushion)	ゴム付ボルト	1
6	104	Nut for 103	ナット	1
7	117	Pin for Cover Cushion	カバークッションピン	3
8	114	Nut for 68917	ナット	6
9	68931	Name Plate	銘板	1
10	125	Rivet for 68931	止メ銀	4
11	68913	Presser Foot Lifting Shaft	押工揚ゲシャフト	1
12	68916	Presser Foot Lifting Link Lever	押工揚ゲリンクレバー	1
13	111	Screw for 68916, 68915, 68906, 68918	止ネジ	5
14	68919	Presser Foot Lifting Link	押工揚ゲリンク	1
15	115	Screw for 68918	押工揚ゲリンク止ネジ	1
16	68907	Shaft Lever Spring Hanging Piece	バネ掛ケ片	1
17	112	Washer for 68907, 68914, 68928, 68929	ワッシャ	8
18	110	Screw for 68907	バネ掛ケ片止ネジ	1
19	68909	Presser Foot Lifting Shaft Lever Spring	押工揚ゲシャフトレバーバネ	1
20	68933	Switch Board	スイッチ取付板	1
21	127	Washer for 68933	ワッシャ	2
22	126	Screw for 68933	スイッチ取付板止ネジ	2
23		Switch	スイッチ	1
24	133	Screw for Switch	スイッチ止ネジ	2
25	124	Spring Washer for Switch	スプリングワッシャ	2
26	134	Nut for Switch	ナット	2
27	68915	Presser Foot Lifting Shaft Lever	押工揚ゲシャフトレバー	1
28	68908	Presser Foot Lifting Connecting Rod Spring	押工揚ゲ連結棒バネ	1
29	68906	Connecting Rod Positioning Collar (Upper)	押工揚ゲ連結棒カラー(上)	1
30	68910	Rubber Pipe	ゴムパイプ	1
31	68918	Connecting Rod Positioning Collar (Lower)	押工揚ゲ連結棒カラー(下)	1
32	68914	Presser Foot Lifting Connecting Rod	押工揚ゲ連結棒	1
33	113	Cotter Pin	割ピン	1
34	68911	Presser Foot Pedal Lever	押工揚ゲペダルレバー	1
35	68912	Motor Pedal Lever	モータペダルレバー	1
36	68905	Column	コラム	1
37	68927	Table Support Ring Unit	テーブルサポートリング(組)	1
38	118	Screw for 68927	テーブルサポートリング止ネジ	2
39	120	Toothed Washer for 68927	菊ワッシャ	2
40	121	Nut for 68927	ナット	2
41	68928	Table Support (Short)	テーブルサポート(短)	1
42	68929	Table Support (Long)	テーブルサポート(長)	1
43	122	Screw for 68928, 68929	テーブルサポート止ネジ	6
44	68939	Table	テーブル	1
45	132	Screw for 68939	テーブル止ネジ	6
46	68900	Basement	ベース	1
47	68924	Pedal Lever Collar	ペダルレバーカラー	4
48	109	Screw for 68924, 68904, 68903	止ネジ	8
49	68904	Motor Pedal	モータペダル	1
50	68903	Presser Foot Pedal	押工揚ゲペダル	1
51	68942	Basement Rubber Cushion	ベースクッション	4

1

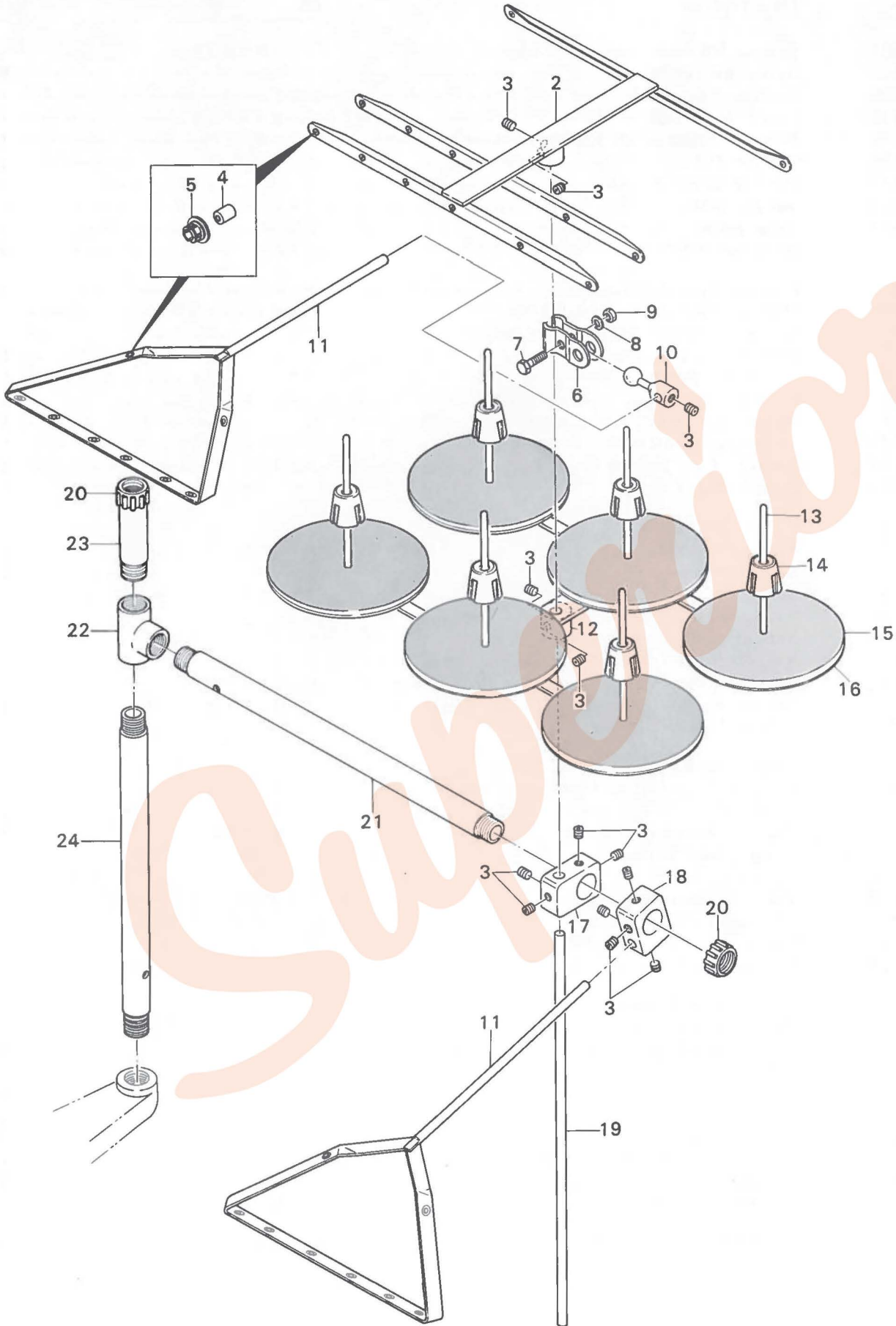

Ref. No.	Parts No.	Description	品名	Amt. Req.
1	99100	Thread Stand, Complete Set	糸立台(組)	1
2	99101	Thread Hanger	スレッドハンガ	1
3	142	Screw for 99101, 99103, 99105, 99108, 99109	止ネジ	13
4	68358	Thread Eyelet	糸案内糸道	31
5	68359	Thread Eyelet Bushing	糸案内糸道ブッシュ	31
6	99102	Thread Guide Adjusting Ball Holder	糸案内調節球支工	1
7	143	Screw for 99102	糸案内調節球支工止ネジ	1
8	162	Washer for 99102	ワッシャ	1
9	161	Nut for 99102	ナット	1
10	99103	Thread Guide Adjusting Ball	糸案内調節球	1
11	99104	Thread Guide	糸案内	2
12	99105	Thread Stand	糸立台	1
13	99066	Spool Pin	スプール軸	6
14	99065	Spool Cushion	スプールクッション	6
15	99106	Spool Mat	スプールマット	6
16	99107	Spool Seat Disc	受ケ皿	6
17	99108	Thread Stand Bar Black	糸立棒ブロック	1
18	99109	Thread Guide Block	糸案内ブロック	1
19	99110	Thread Stand Bar	糸立棒	1
20	99111	Insulating Bushing	絶縁ブッシュ	2
21	99112	Thread Stand Pipe (Long)	糸立パイプ(長)	1
22	99113	Pipe Joint	管継手	1
23	99114	Cord Pipe	コードパイプ	1
24	99115	Thread Stand Pipe (Short)	糸立パイプ(短)	1

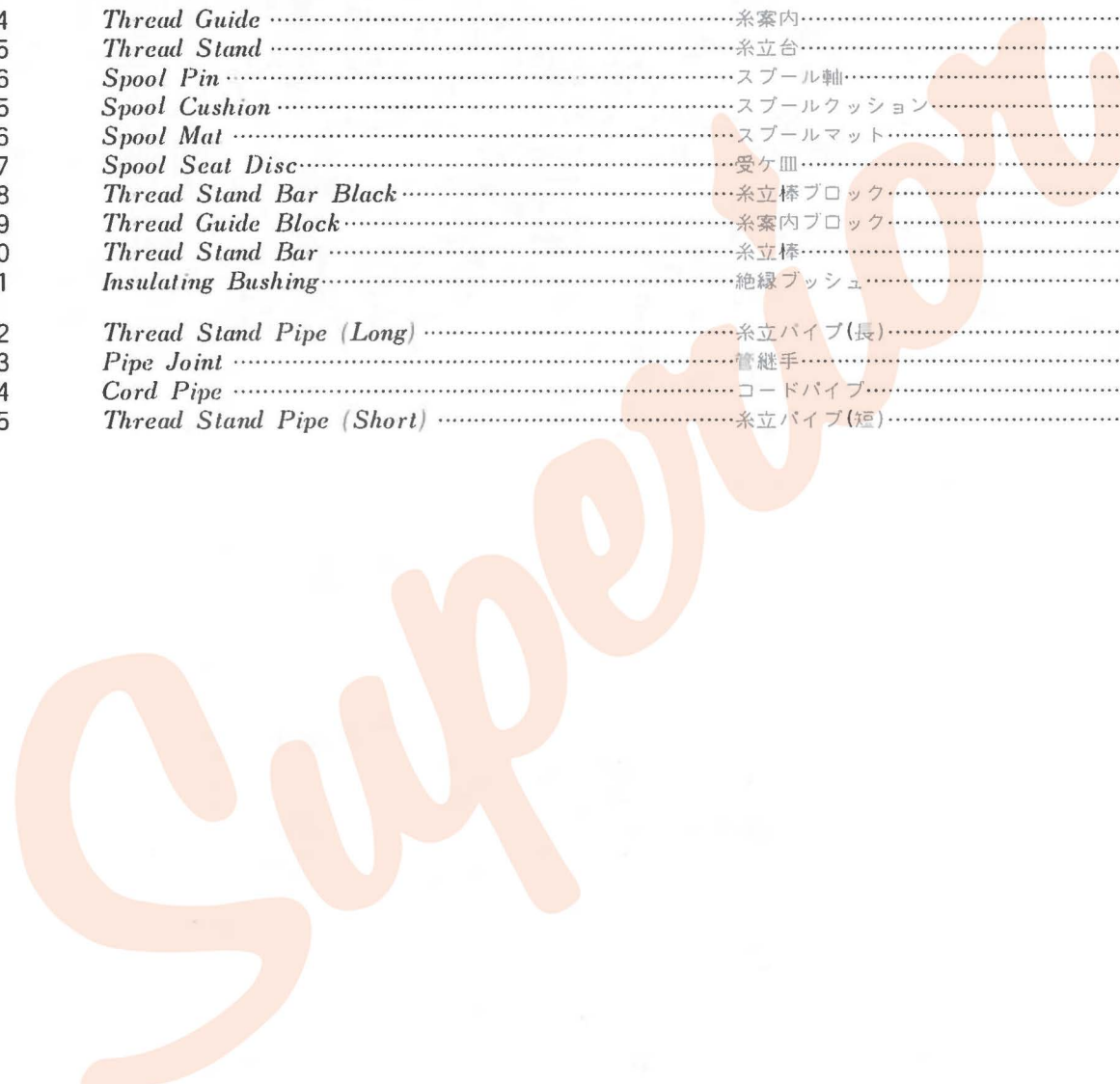

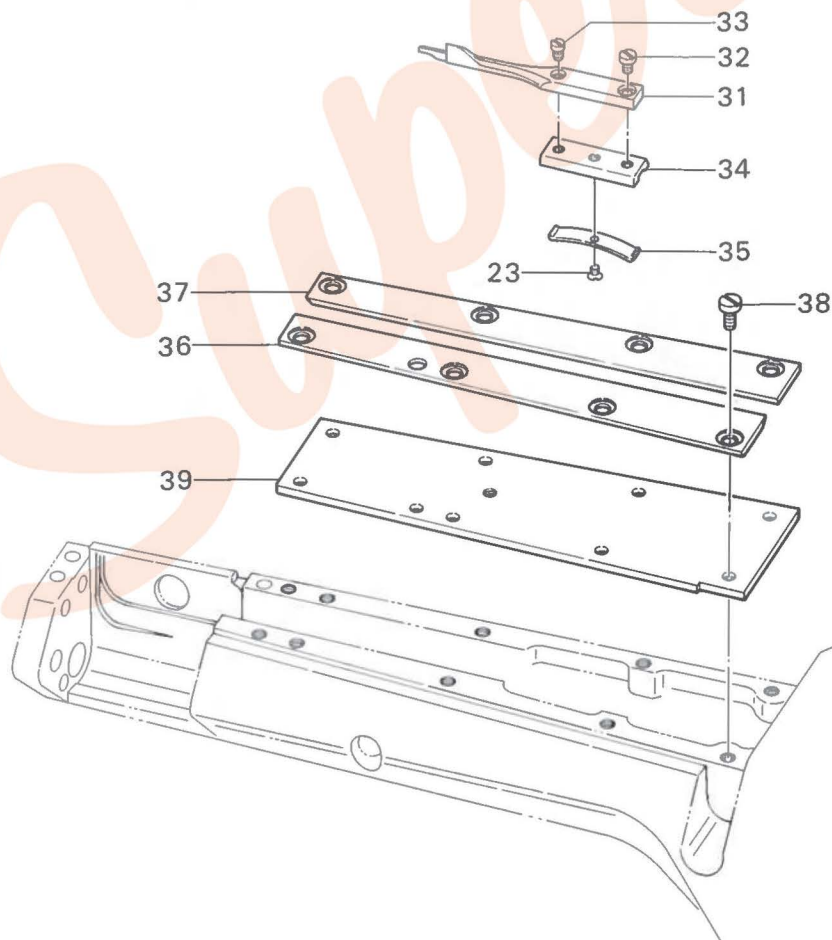
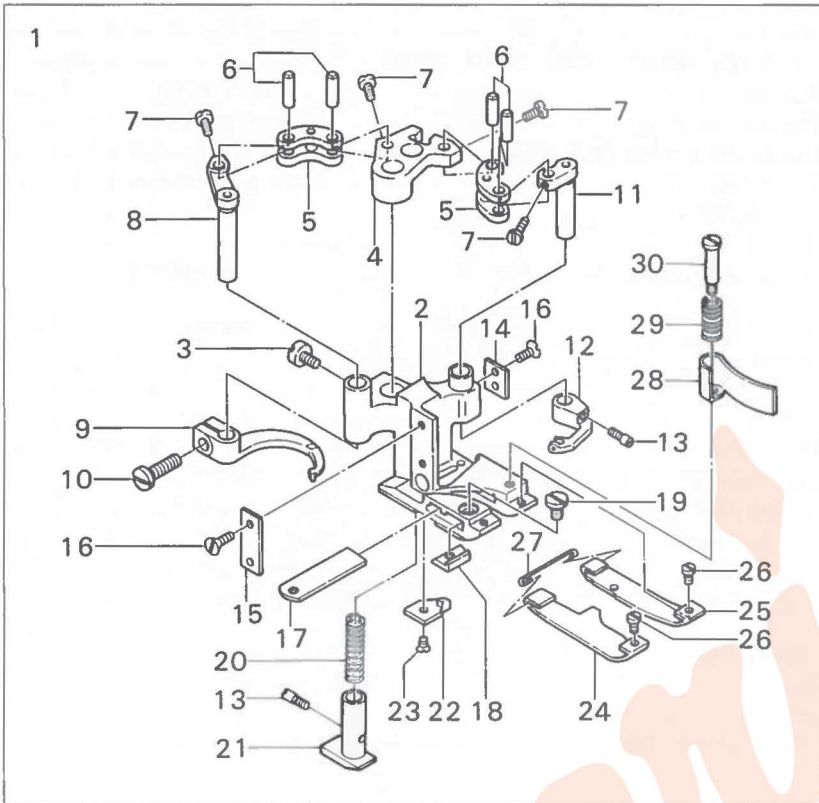



Ref. No.	Parts No.	Description	品名	Amt. Req.
1	68459	Presser Foot, Complete Set	押エ(組)	1
2	68461	Presser Foot	押エ	1
3	9853	Screw for 68461	押エ止ネジ	1
4	68127	Thread Carrier and Hook Driving Segment	キャリア・フックセグメント	1
5	68128	Thread Carrier and Hook Driving Lever Link	キャリア・フックレバーリンク	2
6	68129	Thread Carrier and Hook Driving Lever Link Pin	キャリア・フックレバーリンクピン	4
7	4172	Screw for 68129	キャリア・フックレバーリンクピン止ネジ	4
8	68126	Thread Hook Driving Lever	飾り糸フックレバー	1
9	68124	Ornamental Thread Hook	飾り糸フック	1
10	4185	Screw for 68124	飾り糸フック止ネジ	1
11	68125	Ornamental Thread Carrier Driving Lever	飾り糸キャリアレバー	1
12	68123	Ornamental Thread Carrier	飾り糸キャリア	1
13	4180	Screw for 68123, 68116	止ネジ	2
14	68346	Presser Foot Attach Piece (Right)	押エガイド板(右)	1
15	68347	Presser Foot Attach Piece (Left)	押エガイド板(左)	1
16	4154	Screw for 68346, 68347	止ネジ	4
17	68121	Lower Knife	下メス	1
18	68122	Lower Knife Clamp	下メスクランプ	1
19	1227	Screw for 68122	下メスクランプ止ネジ	1
20	68117	Yielding Section Spring	小押エバネ	1
21	68116	Yielding Section	小押エ	1
22	68474	Cloth Guide Plate	布ガイド	1
23	4182	Screw for 68474, 68471	止ネジ	2
24	68464	Presser Foot Spring Plate (C) (Left)	押エ板バネ(C) (左)	1
25	68465	Presser Foot Spring Plate (C) (Right)	押エ板バネ(C) (右)	1
26	4173	Screw for 68464, 68465	止ネジ	2
27	68120	Spring Plate Holder	押エ板バネホルダ	1
28	68187	Chip Guard	チップガード	1
29	68189	Chip Guard Spring	チップガードバネ	1
30	4166	Screw for 68187	チップガード止ネジ	1
31	68469	Lap Former	ラップフォーマ	1
32	4172	Screw for 68469	ラップフォーマ止ネジ	1
33	1228	Screw for 68469	ラップフォーマ止ネジ	1
34	68470	Lap Former Slide Block	ラップフォーマ台	1
35	68471	Lap Former Slide Block Spring	ラップフォーマ台バネ	1
36	68472	Lap Former Guide Plate (Left)	ラップフォーマガイド板(左)	1
37	68473	Lap Former Guide Plate (Right)	ラップフォーマガイド板(右)	1
38	4134	Screw for 68472, 68473	止ネジ	8
39	68463	Sewing Cylinder Cover (Upper)	シリンダ上カバー	1

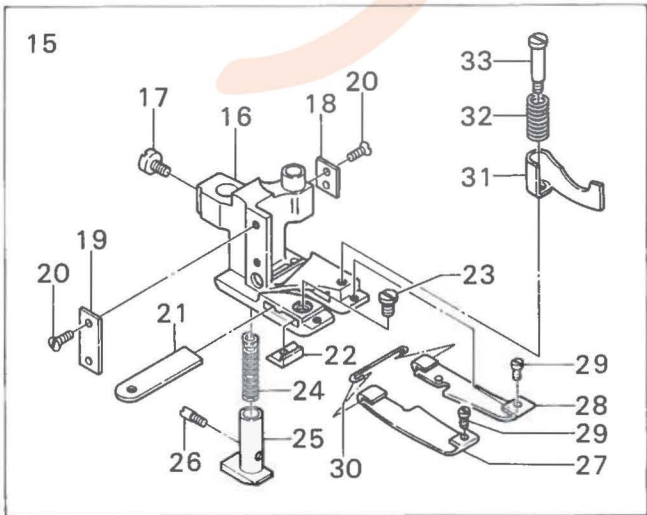
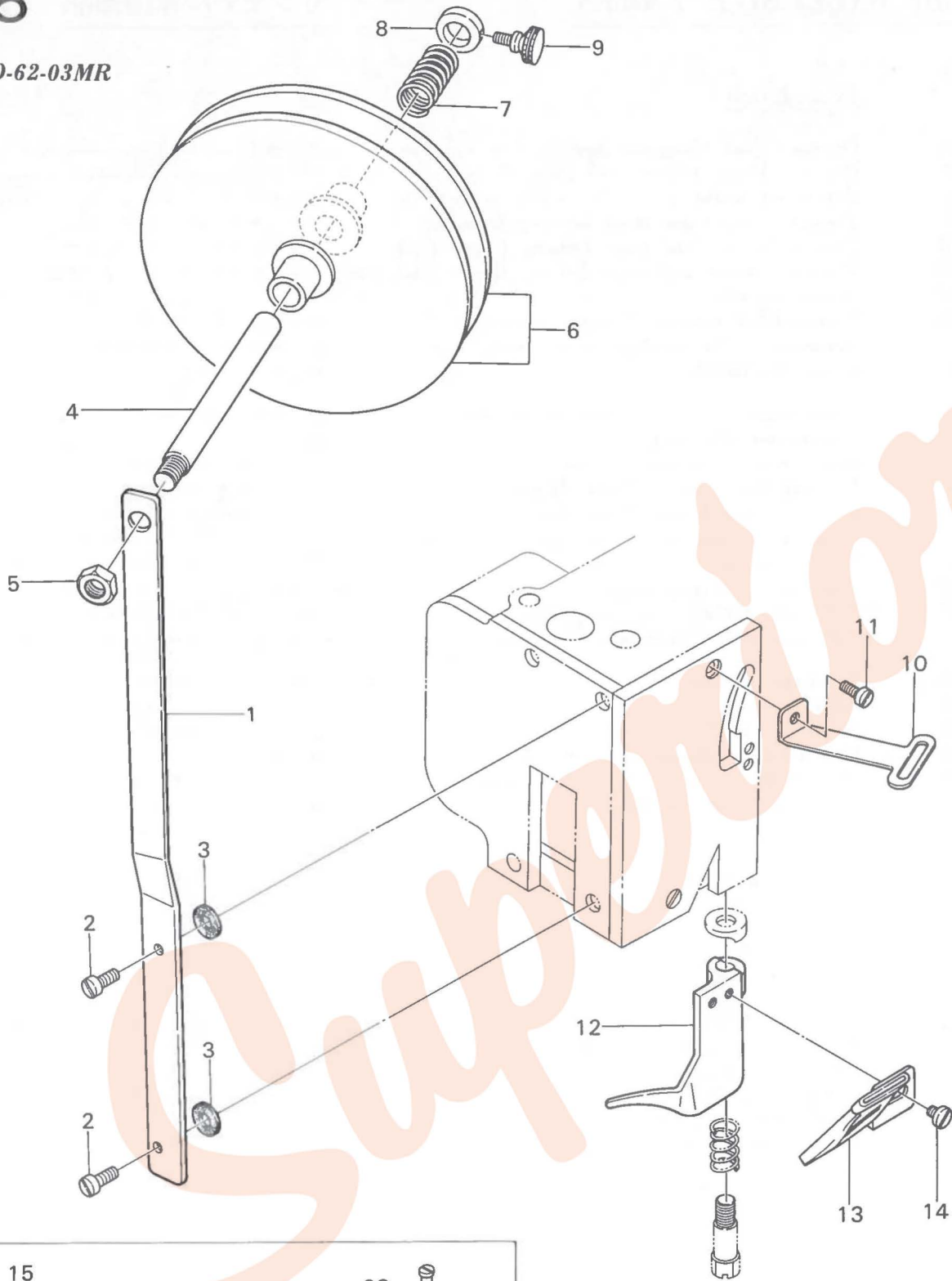

Ref. No.	Parts No.	Description	品 名	Amt. Req.
1	68427	Tape Reel Support	テープリール取付板	1
2	7405	Screw for 68427	テープリール取付板止ネジ	2
3	568	Rubber Cushion for 68427	ゴムクッション	2
4	68428	Tape Reel Shaft	テープリール軸	1
5	145	Nut for 68428	ナット	1
6	11168	Tape Reel	テープリール	2
7	68432	Tape Reel Spring	テープリールスプリング	1
8	32719	Tape Reel Collar	テープリールカラー	1
9	6434	Screw for 32719	テープリールカラー止ネジ	1
10	68429	Tape Guide	テープガイド	1
11	1175	Screw for 68429	テープガイド止ネジ	1
12	68426	Frame Chip Guard	フレームチップガード	1
13	68431	Folder	定規	1
14	1203	Screw for 68431	定規止ネジ	2
15	68419	Presser Foot, Complete Set	押工(組)	1
16	68421	Presser Foot	押工	1
17	9853	Screw for 68421	押工止ネジ	1
18	68346	Presser Foot Attach Piece (Right)	押工ガイド板(右)	1
19	68347	Presser Foot Attach Piece (Left)	押工ガイド板(左)	1
20	4154	Screw for 68346, 68347	止ネジ	4
21	68121	Lower Knife	下メス	1
22	68122	Lower Knife Clamp	下メスクランプ	1
23	1227	Screw for 68122	下メスクランプ止ネジ	1
24	68117	Yielding Section Spring	小押工バネ	1
25	68116	Yielding Section	小押工	1
26	4180	Screw for 68116	小押工止ネジ	1
27	68423	Presser Foot Spring Plate (D)(Left)	押工板バネ(D)(左)	1
28	68424	Presser Foot Spring Plate (D)(Right)	押工板バネ(D)(右)	1
29	4173	Screw for 68423, 68424	止ネジ	2
30	68120	Spring Plate Holder	押工板バネホルダ	1
31	68425	Chip Guard	チップガード	1
32	68189	Chip Guard Spring	チップガードバネ	1
33	4166	Screw for 68425	チップガード止ネジ	1

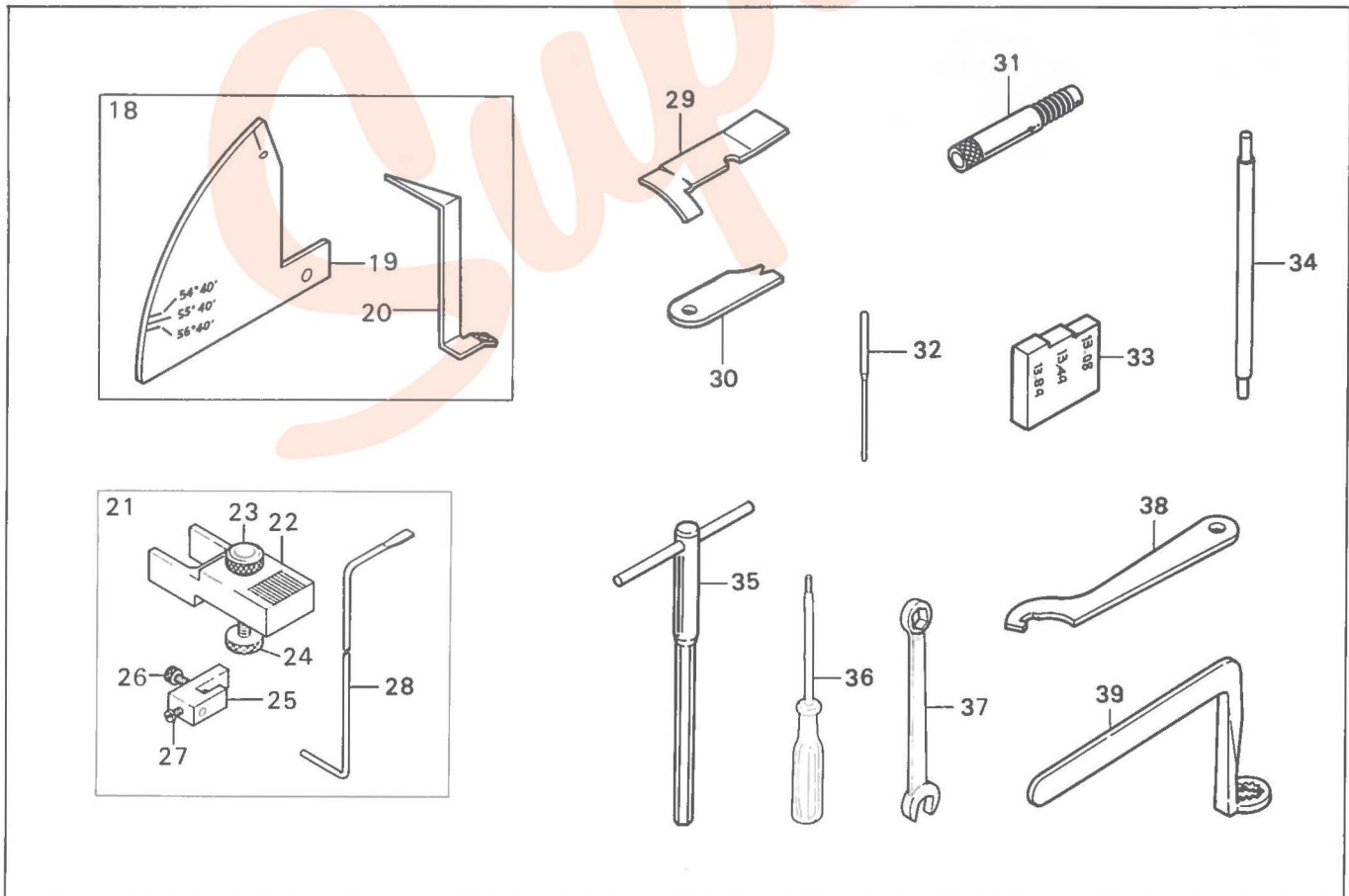
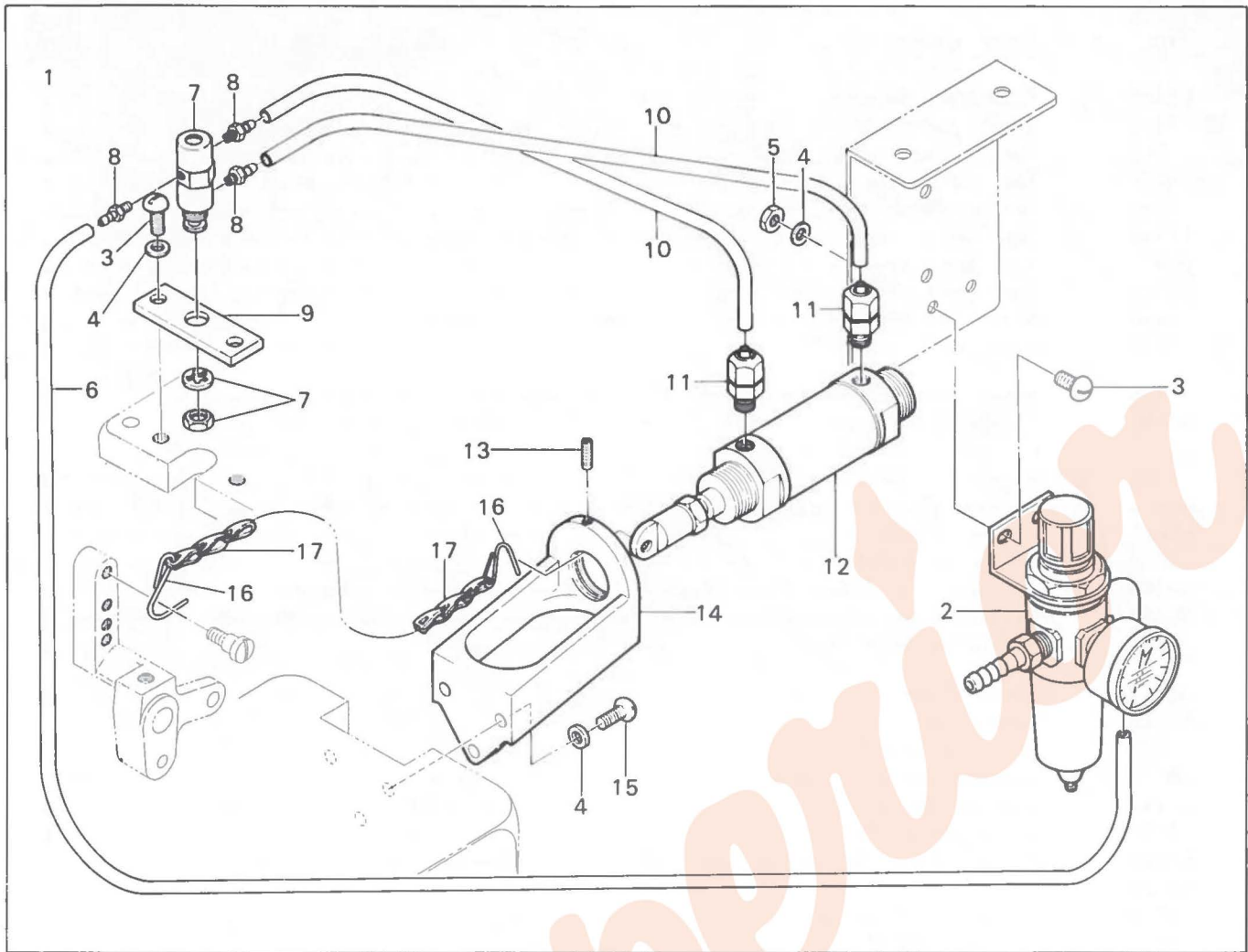

Ref. No.	Parts No.	Description	品名	Amt. Req.
1	68957	Presser Foot Lifter Air Cylinder, Complete Set	押工揚ゲエアシリンダ(組)	1
2	68954	Air Regulator Unit	レギュレータ(組)	1
3	138	Screw for 68954, 68953	止ネジ	4
4	112	Washer for 68954, 68953, 68951	ワッシャ	7
5	139	Nut for 68954	ナット	2
6	68955	Air Pipe (Short)	エアパイプ(短)	2
7	68952	Air Valve Unit	エアバルブ(組)	1
8	10017	Bamboo Joint	bambu継手	3
9	68953	Air Valve Bracket	エアバルブ取付板	1
10	68956	Air Pipe (Long)	エアパイプ(長)	1
11	10060	Joint	コネクタ	2
12	68950	Air Cylinder	エアシリンダ	1
13	136	Screw for 68950	エアシリンダ止ネジ	1
14	68951	Air Cylinder Holder	エアシリンダ取付台	1
15	137	Screw for 68951	エアシリンダ取付台止ネジ	3
16	80932	Chain Hook	チェーンフック	2
17	37912	Chain	鎖	1
18	68365	Looper Rocking Movement Gauge Unit	ルーバ左右運動量ゲージ(組)	1
19	68366	Looper Rocking Movement Gauge Graduations	ルーバ左右運動量目盛板	1
20	68367	Looper Rocking Movement Gauge Pointer	ルーバ左右運動量指針	1
21	68361	Looper and Needle Cynchronizing Gauge Unit	針ルーバタイミングゲージ(組)	1
22	68362	Needle Setting Block	針棒タイミングブロック	1
23	173	Nut for 68362	ナット	1
24	4200	Adjusting Screw for 68362	調節ネジ	1
25	68363	Looper Clamp and Height Gauge	ルーバクランプ	1
26	4201	Screw for 68363	ルーバクランプ止ネジ	1
27	4404	Screw for 68364	止ネジ	1
28	68364	Cynchronizing Gauge Rod	針ルーバタイミングゲージロッド	1
29	68368	Looper Angle Gauge	ルーバ角度ゲージ	1
30	68369	Looper Gauge	ルーバゲージ	1
31	68371	Looper Avoid Gauge Unit	ルーバ前後量調節ゲージ(組)	1
32	68370	Needle Height Test Pin	テストピン	2
33	68360	Needle Height Gauge	針高サゲージ	1
34	68375	Needle Bar Setting Torque Rod	針棒トルクバー	1
35	99096	Hexagonal Wrench Key (T-Handle) (6.35mm) (1/4 inch)	T型キーレンチ	1
36	37923	Hexagonal Screwdriver (1.98mm) (5/64 inch)	キーレンチ付ドライバ	1
37	99097	Wrench (Open and Box Ends) (6.35mm) (1/4 inch)	レンチ	1
38	99098	Pin Wrench	ピンレンチ	1
39	99099	Offset Box Wrench (4.76mm) (3/16 inch)	オフセットボックスレンチ	1

Parts No.	Page No.	Ref. No.	Weight (g)
102	13	2	—
103	13	5	—
104	13	6	—
105	12	15	—
106	12	18	—
107	12	17	—
108	12	14	—
109	13	48	—
110	13	18	—
111	12	30	—
111	13	13	—
112	12	34	—
112	13	17	—
112	17	4	—
113	12	33	—
113	13	33	—
114	13	8	—
115	13	15	—
116	13	4	—
117	13	7	—
118	13	38	—
120	13	39	—
121	13	40	—
122	13	43	—
123	12	25	—
124	12	24	—
124	13	25	—
125	13	10	—
126	13	22	—
127	13	21	—
128	12	4	—
129	12	21	—
130	12	10	—
131	12	12	—
132	13	45	—
133	13	24	—
134	13	26	—
136	17	13	—
137	17	15	—
138	17	3	—
139	17	5	—
142	14	3	—
143	14	7	—
145	16	5	2.8
161	12	9	5.5
161	14	9	5.5
162	12	20	3.9
162	14	8	3.9
166	12	27	—
173	17	23	3
187	1	39	0.03
203	5	27	0.01
206	6	7	1.4
278	5	35	0.03

Parts No.	Page No.	Ref. No.	Weight (g)
306	8	28	1.3
306	9	23	1.3
322	1	13	0.3
335	1	40	0.8
340	1	10	0.5
347	7	20	1
355	7	31	0.9
355	8	25	0.9
355	9	8	0.9
356	7	29	0.8
356	8	9	0.8
356	9	6	0.8
363	7	8	1
390	4	24	0.3
463	4	8	0.2
464	4	13	—
465	11	4	—
470	8	23	0.5
471	7	18	1.5
472	1	21	0.8
474	1	28	0.3
474	9	22	0.3
474	11	18	0.3
475	10	41	0.1
477	8	3	0.2
478	2	4	6.1
479	1	35	6.9
480	2	23	0.6
482	3	14	0.7
484	1	5	0.02
485	3	17	4.7
486	2	29	0.4
487	10	42	0.2
488	10	45	0.2
489	8	41	0.04
530	5	10	0.3
532	3	7	0.3
532	11	25	0.3
548	8	33	0.1
550	11	5	0.03
568	16	3	0.13
586	8	8	1.3
693	3	29	0.3
755	9	15	0.2
1170	5	28	1
1170	7	28	1
1170	8	21	1
1170	9	10	1
1174	7	17	1
1175	7	36	0.9
1175	16	11	0.9

Parts No.	Page No.	Ref. No.	Weight (g)
1196	2	34	0.5
1196	3	61	0.5
1203	2	27	0.7
1203	16	14	0.7
1208	8	44	0.6
1222	3	40	0.5
1222	5	32	0.5
1222	8	12	0.5
1222	10	11	0.5
1227	6	31	0.3
1227	15	19	0.3
1227	16	23	0.3
1228	15	33	0.2
1457	8	14	0.25
1601	3	10	4
3312	3	65	0.1
3410	2	33	0.35
3410	5	6	0.35
3434	5	8	0.4
3434	10	13	0.4
3473	8	36	0.8
3473	10	31	0.8
3564	7	6	0.7
3635	5	30	0.9
3635	7	47	0.9
3638	9	5	0.5
3646	5	13	0.9
3649	5	12	1.1
3653	7	14	1
4123	5	22	1.5
4134	2	18	1
4134	15	38	1
4141	2	21	0.5
4154	6	28	0.08
4154	15	16	0.08
4154	16	20	0.08
4160	10	27	2.9
4161	10	25	3
4162	9	31	2.9
4163	10	22	1.7
4164	8	17	4.4
4165	8	2	2.1
4166	6	41	1.2
4166	15	30	1.2
4166	16	33	1.2
4167	6	1	13
4168	10	44	0.6
4169	8	42	1.1
4170	5	43	0.1
4171	7	46	0.5
4172	6	19	0.1
4172	15	7	0.1
4172	15	32	0.1

# INDEX

Parts No.	Page No.	Ref. No.	Weight (g)
4173	6	37	0.12
4173	15	26	0.12
4173	16	29	0.12
4174	1	34	8
4175	1	27	10.9
4176	6	10	2.8
4177	5	11	2.5
4178	10	18	2
4179	7	43	0.1
4180	3	38	0.4
4180	6	25	0.4
4180	6	34	0.4
4180	15	13	0.4
4180	16	26	0.4
4181	7	41	0.08
4182	5	47	0.08
4182	15	23	0.08
4183	11	19	1.6
4184	1	15	0.5
4185	5	38	0.7
4185	5	45	0.7
4185	6	22	0.7
4185	7	39	0.7
4185	15	10	0.7
4186	5	15	0.55
4187	3	52	0.2
4188	1	47	7
4189	7	2	2.2
4190	2	30	1.1
4191	3	60	0.4
4192	1	4	14
4193	2	10	21.4
4194	2	5	3.2
4195	1	26	5.2
4196	1	17	6.6
4197	3	50	0.08
4198	11	22	2.7
4200	17	24	6.8
4201	17	26	2.8
4202	4	3	1.7
4203	9	29	2.8
4203	10	33	2.8
4206	3	25	8.6
4245	3	43	0.2
4284	8	46	0.2
4312	2	8	0.6
4313	5	36	0.4
4321	3	64	1
4321	10	15	1
4352	1	7	1.3
4352	8	34	1.3
4353	1	50	0.9
4353	11	24	0.9
4358	1	11	0.9
4358	3	8	0.9

Parts No.	Page No.	Ref. No.	Weight (g)
4358	7	11	0.9
4404	17	27	0.2
4437	6	4	1.5
4440	3	2	1.5
4440	4	14	1.5
4440	10	9	1.5
4441	9	3	2.2
4445	1	3	1.7
4551	10	35	4
4552	3	13	2.5
4552	7	4	2.5
5004	10	5	2.3
5040	8	40	2
5047	9	28	1.1
5070	5	24	5
5076	1	25	8
5076	11	35	8
5550	8	38	2.9
5650	6	12	2.8
5650	11	33	2.8
6434	16	9	5.5
7311	3	59	1.9
7405	2	36	1.2
7405	16	2	1.2
7605	11	8	1
7609	7	22	1.2
7609	8	30	1.2
7609	9	13	1.2
7619	3	35	0.3
7619	5	20	0.3
7621	1	32	0.5
7621	2	13	0.5
7621	10	40	0.5
7650	2	25	0.4
7650	11	16	0.4
8047	5	5	0.5
9104	1	20	0.8
9142	1	42	0.5
9150	11	20	2
9209	6	6	0.5
9604	10	6	0.9
9730	3	55	0.6
9853	1	9	1.8
9853	6	15	1.8
9853	15	3	1.8
9853	16	17	1.8
10017	17	8	—
10060	17	11	—
11168	16	6	—
20472	10	14	0.08

Parts No.	Page No.	Ref. No.	Weight (g)
20472	11	17	0.08
31111	3	23	5
32339	3	46	3.3
32421	1	24	0.1
32421	11	34	0.1
32719	16	8	5
34406	5	25	7
37912	17	17	—
37923	17	36	—
63009	12	5	17.6
68001	1	19	10.72kg
68002	1	33	1.25kg
68003	1	31	4.8
68004	1	30	3.7
68005	2	1	2.67kg
68006	2	2	6.1
68007	2	3	8
68008	1	1	362
68009	1	2	9.4
68011	1	6	1.1
68012	1	8	59
68013	1	12	0.7
68014	1	14	15.2
68018	1	16	134
68019	1	18	4.8
68020	1	23	22.5
68021	1	22	1
68022	1	48	110
68023	1	41	103
68024	2	16	145
68025	2	17	2.6
68026	2	19	0.06
68027	2	20	0.6
68030	2	7	43.2
68031	2	6	1.5
68032	2	9	4
68033	5	2	0.2
68033	7	23	0.3
68035	4	25	3.3
68037	5	21	320
68038	5	16	398
68039	5	1	178
68040	5	9	131
68043	5	7	22
68044	4	1	444
68047	4	2	0.4
68048	4	4	48
68049	4	5	41
68050	4	6	23
68053	5	40	9
68054	5	39	21
68055	4	18	7.9
68056	4	19	5.2
68057	5	37	9.3

# INDEX

Parts No.	Page No.	Ref. No.	Weight (g)
68058	5	29	107
68059	5	26	12
68060	5	23	62
68061	5	44	39
68062	5	46	0.3
68063	9	1	102
68064	9	4	15
68065	9	2	29.6
68066	9	7	17.2
68068	9	11	18
68069	8	29	3.1
68069	9	12	3.1
68070	9	16	102
68071	9	17	23.5
68073	9	18	18.5
68074	9	19	14
68075	9	20	7.2
68076	9	21	2.5
68077	9	26	91.5
68078	10	30	39
68079	9	24	0.1
68079	10	29	0.1
68079	11	6	0.1
68080	9	27	4.5
68080	10	32	4.5
68082	10	34	23
68083	10	17	2.2
68084	10	20	34
68085	10	23	65
68086	10	21	44
68087	10	24	2
68088	10	19	52.5
68089	10	12	18
68090	10	16	8
68091	10	3	137
68092	10	2	143
68093	10	4	8.4
68094	2	22	0.08
68095	10	7	10.5
68096	10	8	11
68097	10	10	1.4
68098	10	28	17.8
68099	10	26	9
68101	10	37	8.5
68103	10	39	21.5
68104	10	38	0.9
68105	10	43	12
68106	10	1	306
68107	10	36	2.8
68108	4	23	2.7
68111	6	13	104
68112	6	14	49.5
68116	6	33	4.8
68116	15	21	4.8

Parts No.	Page No.	Ref. No.	Weight (g)
68116	16	25	4.8
68117	6	32	0.2
68117	15	20	0.2
68117	16	24	0.2
68118	6	35	1.2
68119	6	36	1.2
68120	6	38	0.2
68120	15	27	0.2
68120	16	30	0.2
68121	6	29	1.7
68121	15	17	1.7
68121	16	21	1.7
68122	6	30	0.6
68122	15	18	0.6
68122	16	22	0.6
68123	6	24	1.9
68123	15	12	1.9
68124	6	21	4.9
68124	15	9	4.9
68125	6	23	4.5
68125	15	11	4.5
68126	6	20	6
68126	15	8	6
68127	6	16	7.6
68127	15	4	7.6
68128	6	17	4
68128	15	5	4
68129	6	18	0.8
68129	15	6	0.8
68130	6	8	40.8
68131	4	17	37.2
68132	6	2	6.6
68133	6	3	19
68134	6	5	8.1
68135	6	9	18
68136	6	11	21.5
68137	7	3	80.2
68138	7	9	12
68139	4	12	10.5
68140	7	7	7.6
68141	7	5	43
68142	7	10	27.8
68143	7	13	27
68144	7	15	19.5
68145	5	18	35
68146	5	17	6
68147	5	19	5
68148	7	16	41
68149	7	1	12.3
68150	7	21	13
68151	7	34	48
68152	4	15	33.8
68153	4	16	1.1
68154	7	12	17.8
68157	6	42	1.3

Parts No.	Page No.	Ref. No.	Weight (g)
68158	6	43	1.5
68167	7	24	84.8
68168	4	10	16.5
68169	4	9	23
68170	4	11	7.1
68171	7	26	6
68171	8	22	6
68172	7	27	14.8
68173	7	32	15
68174	7	19	5.4
68175	7	30	8.5
68175	8	24	8.5
68176	7	25	2.9
68178	7	33	151
68180	7	40	12.4
68181	7	37	1.4
68182	7	38	6
68183	7	45	8
68184	7	44	2.9
68185	7	42	2.8
68187	6	39	2
68187	15	28	2
68189	6	40	0.2
68189	15	29	0.2
68189	16	32	0.2
68191	1	45	36
68193	1	46	0.8
68196	1	44	2.4
68197	8	1	6
68198	8	7	32
68199	8	6	4
68199	9	33	4
68200	8	5	5.2
68201	8	4	41.2
68202	8	10	0.3
68203	8	18	58.5
68204	8	15	26.5
68205	8	11	4.5
68206	8	16	0.08
68207	8	13	4.7
68208	8	19	62.3
68209	8	20	14
68210	8	26	18
68210	9	9	18
68212	8	27	10.1
68213	8	31	145
68214	4	21	18
68215	4	22	12
68216	8	39	8.6
68217	8	43	4.3
68218	8	45	1.8
68219	9	30	43
68220	9	34	29
68221	9	32	3



# INDEX

Parts No.	Page No.	Ref. No.	Weight (g)
68222	8	32	44
68223	8	35	7
68224	8	37	10.9
68225	2	28	15.4
68226	2	26	0.5
68227	2	24	5.5
68228	9	35	1.9
68230	4	20	4
68233	3	12	29
68234	3	16	325
68235	3	15	6.6
68242	3	53	0.6
68243	3	20	0.9
68244	3	19	0.9
68245	3	21	1.4
68246	3	56	35
68249	3	58	1.3
68250	3	59	7.7
68251	3	62	0.4
68252	3	63	7.7
68253	5	3	30.5
68254	5	4	40
68255	3	44	34.5
68256	3	41	0.6
68257	3	42	0.6
68258	3	39	10.5
68259	3	36	14
68260	3	37	7.2
68261	3	47	1.1
68262	3	45	41
68265	2	35	0.8
68267	3	54	0.9
68268	5	31	6.3
68269	3	48	4.6
68270	3	49	0.8
68271	2	31	2.3
68272	2	32	2.1
68273	3	18	2.1
68276	5	14	10
68277	11	15	20.6
68278	11	11	111
68279	11	14	2
68280	11	13	7.3
68281	11	12	2
68282	11	21	58.3
68284	11	10	156
68287	11	26	15.3
68289	11	36	0.4
68290	11	7	37
68294	11	9	0.45
68296	11	3	70
68298	11	23	48
68303	11	1	8.1
68304	11	2	0.9

Parts No.	Page No.	Ref. No.	Weight (g)
68306	1	36	17
68307	1	29	9.1
68308	1	43	1.2
68323	1	37	0.3
68324	3	51	3.4
68330	2	14	2.4
68338	2	12	31
68339	2	11	3.8
68340	11	32	120
68341	11	31	2.9
68342	11	30	2.7
68343	11	29	1.5
68344	11	28	0.08
68345	9	25	37
68346	6	26	0.4
68346	15	14	0.4
68346	16	18	0.4
68347	6	27	0.9
68347	15	15	0.9
68347	16	19	0.9
68348	7	35	15.6
68349	3	33	22.8
68350	3	28	9.4
68351	3	34	35
68352	3	31	0.9
68353	3	30	0.3
68354	1	38	12.5
68355	3	27	69
68356	3	1	90.2
68357	3	9	34
68358	3	4	0.4
68358	14	4	0.4
68359	3	3	0.2
68359	14	5	0.2
68360	17	33	5.3
68361	17	21	64.7
68362	17	22	40.5
68363	17	25	5.3
68364	17	28	6.1
68365	17	18	91
68366	17	19	85.2
68367	17	20	5.8
68368	17	29	8.5
68369	17	30	2.7
68370	17	32	0.3
68371	17	31	29.3
68375	17	34	5.9
68400	2	15-1	0.1
68410	3	11	108
68411	3	24	39.5
68412	3	26	2.2
68413	3	22	1.7
68419	16	15	—
68420	16	16	—

Parts No.	Page No.	Ref. No.	Weight (g)
68423	16	27	—
68424	16	28	—
68425	16	31	—
68426	16	12	—
68427	16	1	—
68428	16	4	—
68429	16	10	—
68431	16	13	—
68432	16	7	—
68433	2	15-2	—
68459	15	1	—
68461	15	2	—
68463	15	39	—
68464	15	24	—
68465	15	25	—
68469	15	31	—
68470	15	34	—
68471	15	35	—
68472	15	36	—
68473	15	37	—
68474	15	22	—
68475	2	15-3	—
68900	13	46	—
68901	13	1	—
68902	12	13	—
68903	13	50	—
68904	13	49	—
68905	13	36	—
68906	13	29	—
68907	13	16	—
68908	13	28	—
68909	13	19	—
68910	13	30	—
68911	13	34	—
68912	13	35	—
68913	13	11	—
68914	12	32	—
68914	13	32	—
68915	13	27	—
68916	13	12	—
68917	12	16	—
68918	13	31	—
68919	13	14	—
68920	12	29	—
68921	12	28	—
68922	12	26	—
68923	12	31	—
68924	13	47	—
68925	13	3	—
68926	12	1	—
68927	13	37	—
68928	13	41	—
68929	13	42	—
68930	12	23	—

# INDEX

<u>Parts No.</u>	<u>Page No.</u>	<u>Ref. No.</u>	<u>Weight (g)</u>
68931	13	9	—
68932	12	2	—
68933	13	20	—
68934	12	8	—
68935	12	3	—
68936	12	9	—
68937	12	11	—
68938	12	6	—
68939	13	44	—
68942	13	51	—
68950	17	12	—
68951	17	14	—
68952	17	7	—
68953	17	9	—
68954	17	2	—
68955	17	6	—
68956	17	10	—
68957	17	1	—
80932	17	16	—
90320	5	34	3.1
90321	5	33	10
93059	1	49	0.01
93528	3	6	3
93538	3	5	10
99065	14	14	—
99066	14	13	—
99096	17	35	—
99097	17	37	—
99098	17	38	—
99099	17	39	—
99100	14	1	—
99101	14	2	—
99102	14	6	—
99103	14	10	—
99104	14	11	—
99105	14	12	—
99106	14	15	—
99107	14	16	—
99108	14	17	—
99109	14	18	—
99110	14	19	—
99111	14	20	—
99112	14	21	—
99113	14	22	—
99114	14	23	—
99115	14	24	—

<u>Parts No.</u>	<u>Page No.</u>	<u>Ref. No.</u>	<u>Weight (g)</u>
------------------	-----------------	-----------------	-------------------

<u>Parts No.</u>	<u>Page No.</u>	<u>Ref. No.</u>	<u>Weight (g)</u>
------------------	-----------------	-----------------	-------------------

Superior

Superior

From the library of: Diamond Needle Corp